

AKE 100/1



Short description

Automatic cellar dehumidification, DN 100, air flow volume 92 m³/h

Application examples

Cellar and/or cellar room, Utility room, Drying room, Utility room

Article number 0084.0458

Technical data

Air flow volume	92 m³/h
Rotating speed	2.500 1/min
Speed controllable	–
Reversing capacity	–
SEC average	-24,18 kWh/(m²·a)
Type of voltage	Alternating current
Rated voltage	230 V
Frequency	50 Hz
Nominal output	8 W
Stand-by power consumption	2 W
I _{max}	0,06 A
Degree of protection	IP X4
Mains cable	5 x 1,5 mm²
Installation site	Wall
Installation site	Cellar / Garage
Type of installation	Surface-mounted
Installation position	any
Material	Synthetic material
Colour	Traffic white, similar to RAL 9016
Weight	0,85 kg
Weight including packaging	1,13 kg
Shutter	none
Nominal size	100 mm
Cable length	1,5 m
Width	159 mm
Height	159 mm
Depth	130 mm
Width with packaging	225 mm
Height with packaging	225 mm

AKE 100/1

Depth with packaging	200 mm
Airstream temperature at I_{Max}	40 °C
Sound pressure level	32 dB(A) (Distance 3 m, Free-field conditions)
Packing unit	1 piece
Range	A
GTIN (EAN)	4012799844587

Characteristic curve

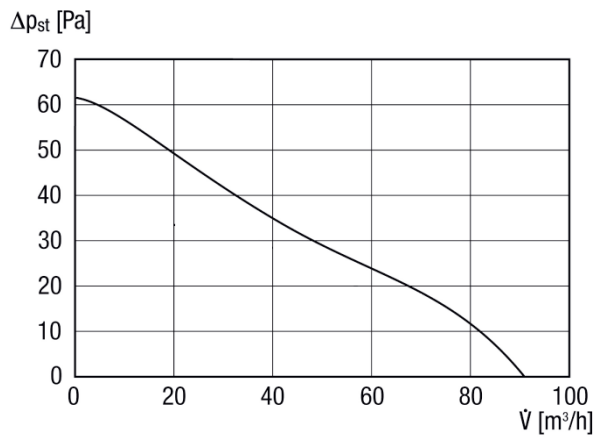

AKE 100/1

Dimensioned drawing [mm]

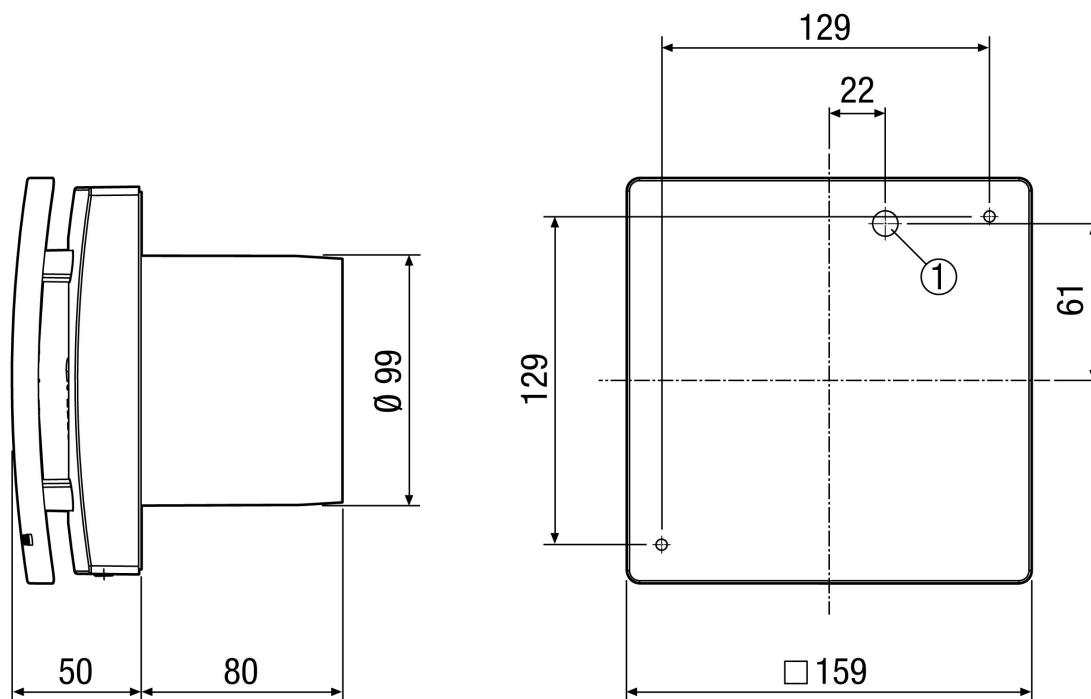

① Cable entry

Dimensioned drawing [mm]

External shutter (included in the scope of delivery)

