

geniovent.x 900 F L-G-SO-K



Short description

Decentralised RLT air handling unit with very good heat recovery. With cross-counterflow heat exchanger and pre-heating register, outside air and outgoing air connections on left, air outlet at top, CO2 sensor integrated in unit. With app for mobile unit control system

Article number 0041.0262

Technical data

| | |
|---|---|
| Air flow volume | 200 m³/h / 830 m³/h |
| SFP value | 0,29 W/(m³/h) |
| Type of voltage | Alternating current |
| Rated voltage | 230 V |
| Frequency | 50 Hz |
| Nominal output | 186 W |
| Stand-by power consumption | < 1 W |
| I _{max} | 15 A |
| Degree of protection | IP 40 |
| Installation site | Inside |
| Material | Sheet steel, galvanised |
| Housing material | Sheet steel, galvanised |
| Heat exchanger material | Synthetic material |
| Inner coating material | Melamine resin foam with fleece |
| Colour | Pure white, similar to RAL 9010 |
| Weight | 200 kg |
| Weight including packaging | 250 kg |
| Filter class | ISO ePM1 50-65% (F7) / ISO ePM10 60% (M5) |
| Connection diameter | 250 mm |
| Connection diameter of condensation drain | 7 mm (inside), 10 mm (outside) |
| Width | 2.100 mm |
| Height | 482 mm |
| Depth | 800 mm |
| Width with packaging | 2.250 mm |
| Height with packaging | 950 mm |
| Depth with packaging | 950 mm |
| Degree of heat provision | 91 % |
| Heat exchanger construction type | Counter current |
| Bypass | Yes |

geniovent.x 900 F L-G-SO-K

| | |
|---|---|
| Frost protection | integrated 1.5 kW |
| Supplementary heating | optional |
| Enthalpy heat exchanger | No |
| Antifreeze circuit | Yes |
| Filter monitoring | with time control |
| CO ₂ regulation (optional) | integrated |
| Smoke gas switch | optional |
| Air quality control (optional) | VOC sensor for geniovent.x |
| Outside air shutters, automatic closing | integrated |
| Presence sensor | PIR motion sensor, optional |
| KNX connection (optional) | K-SM |
| MODBUS interface | integrated |
| BACnet interface | integrated |
| Ethernet interface | integrated |
| Control unit included in scope of delivery. | RB-ZF4 |
| Control unit (optional) | RLS T1 SYS |
| EnOcean wireless integration (optional) | E-SM |
| Sound pressure level | 35 dB(A) (at 0.7 * Vmax and 20 Pa pressure loss each OSA and OGA, with a room attenuation of approx. 16 dB) |
| Packing unit | 1 piece |
| Range | X |
| GTIN (EAN) | 4012799412625 |

Characteristic curve

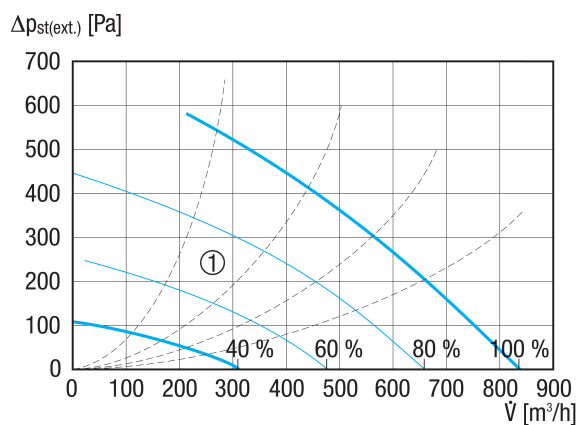

① Configuration range

geniovent.x 900 F L-G-SO-K

Dimensioned drawing [mm]

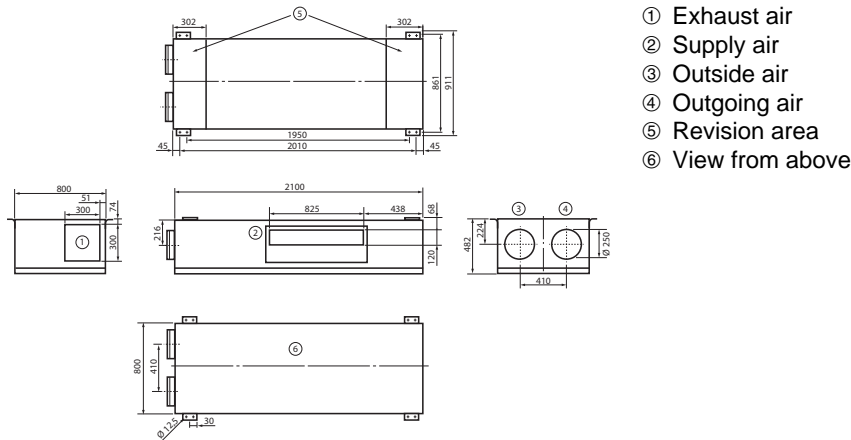

Dimensioned drawing [mm]



- ① Ceiling mounting geniovent.x 600-900 FL. View of the unit from the ceiling.
- ② Optional with fixing bracket rotated by 180°
- ③ Designed for ceiling mounting, e.g. with M10 threaded rods.
- ④ Optional, the fixing bracket can be moved upwards by 36 mm.



geniovent.x 900 F L-G-SO-K

⑤ Optional, the fixing bracket can be moved up by 36 mm and rotated by 180°.