

**AKE/1**

**Circuit diagram for the connection of low-power single-phase motors**

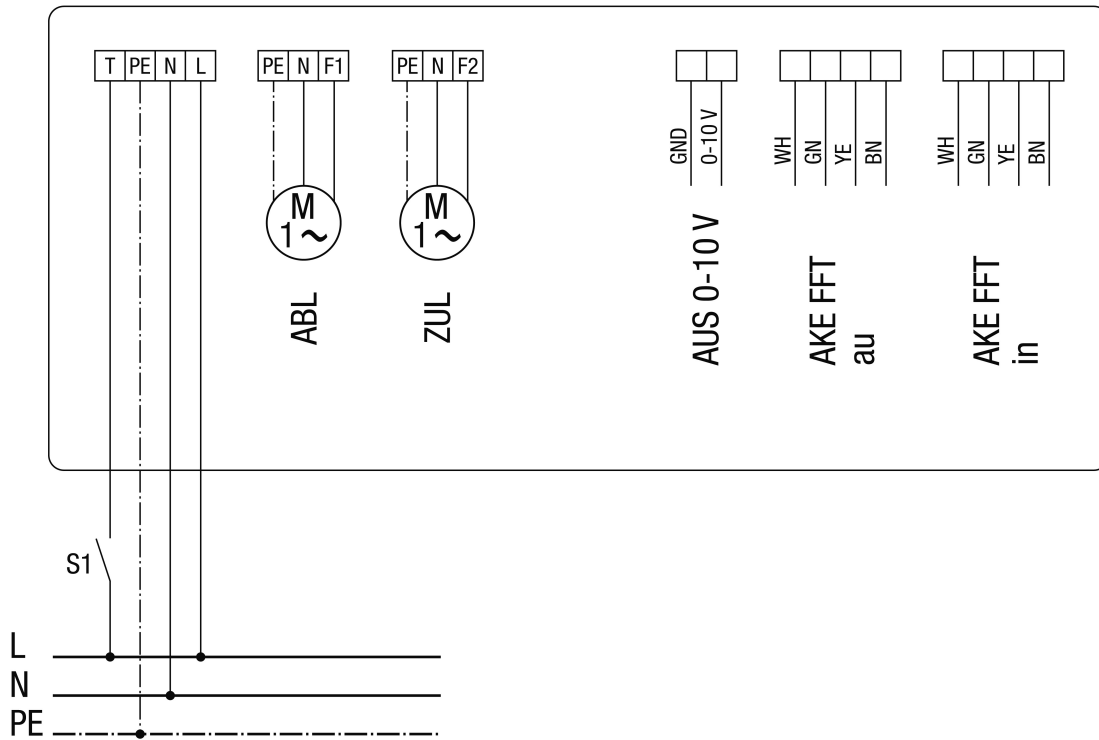

ABL-Exhaust Air  
 ZUL-supply air  
 AUS-Output  
 au-Outside  
 in-Inside  
 S1-External pushbutton / switch (optional)

# WIRING DIAGRAM

## AKE/1



### Circuit diagram for the connection of high-power three-phase motors

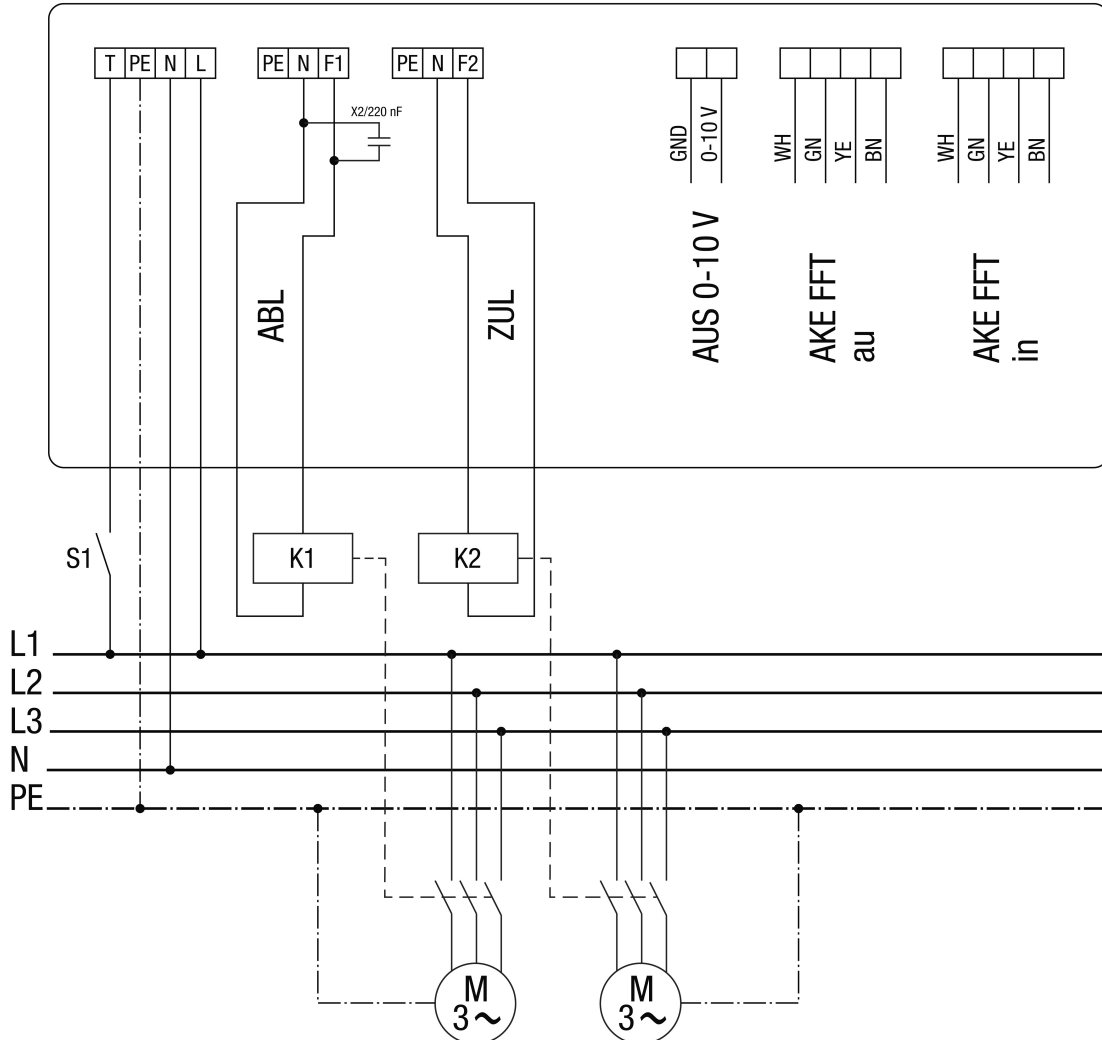

- ABL-Exhaust Air
- ZUL-Supply air
- AUS-Output
- au-Outside
- in-Inside
- K1/K2-Power switch/contactor
- S1-External pushbutton / Switch (optional)
- X2-X2 capacitor, 220nF, Art. No.: E157.0116.0000