

WIRING DIAGRAM

MDR 31 EC

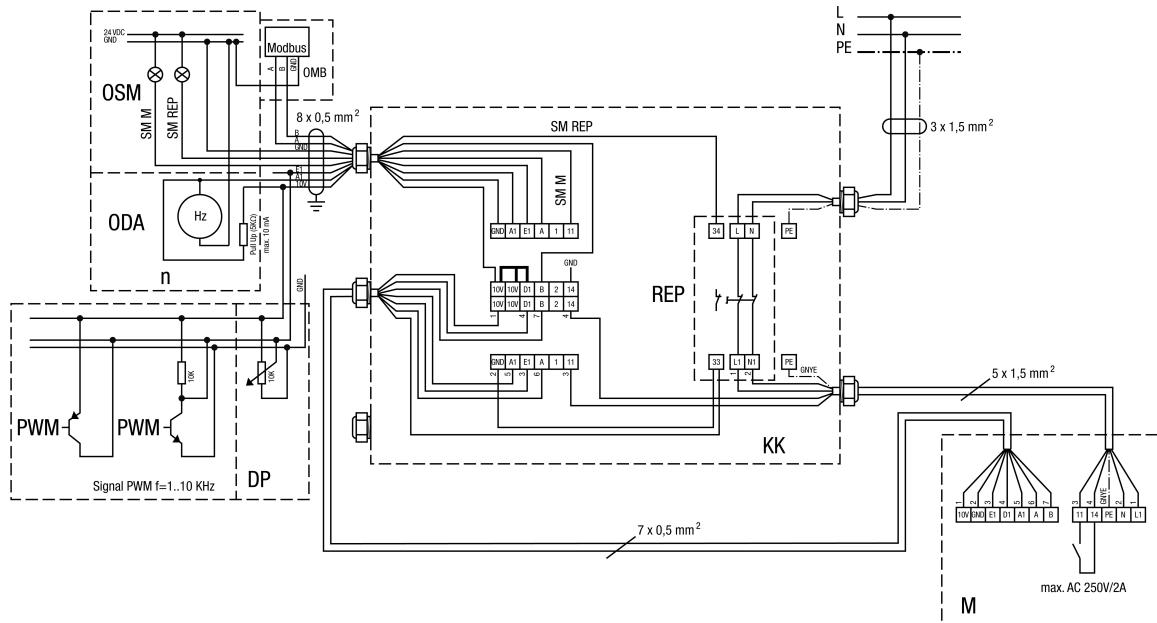

- L/L1, N/N1 - 230V/50Hz power supply
- PE PE conductor
- 10 V / GND - 10 VDC power supply
- E1 - Control voltage Speed input (0-10V)
- D1 - Enabling contact (10V)
- A1 - Speed output
- A/B - MODBUS
- 11/14 - Potential-free contact Motor
- 33/34 - Potential-free contact Repair switch
- 1/2 - Contact not assigned (with connection of a pressure control)
- PWM - PWM speed control
- DP - Speed control potentiometer
- ODA - Option speed evaluation
- n- speed (example: 10 Hz x 60 = 600 rpm, open collector)
- OSM - Fault message option
- SM M – Motor fault signal
- SM REP - Fault message Repair switch
- OMB - Option Modbus (baud rate = 19200, bits = 8, parity = EVEN, stop bits = 1, handshake = none)
- REP - Repair switch
- KK - Terminal box
- M - Motor

WIRING DIAGRAM

MDR 31 EC



MDR 18 / 22 / 25 / 31 with pressure and temperature control system EAT EC

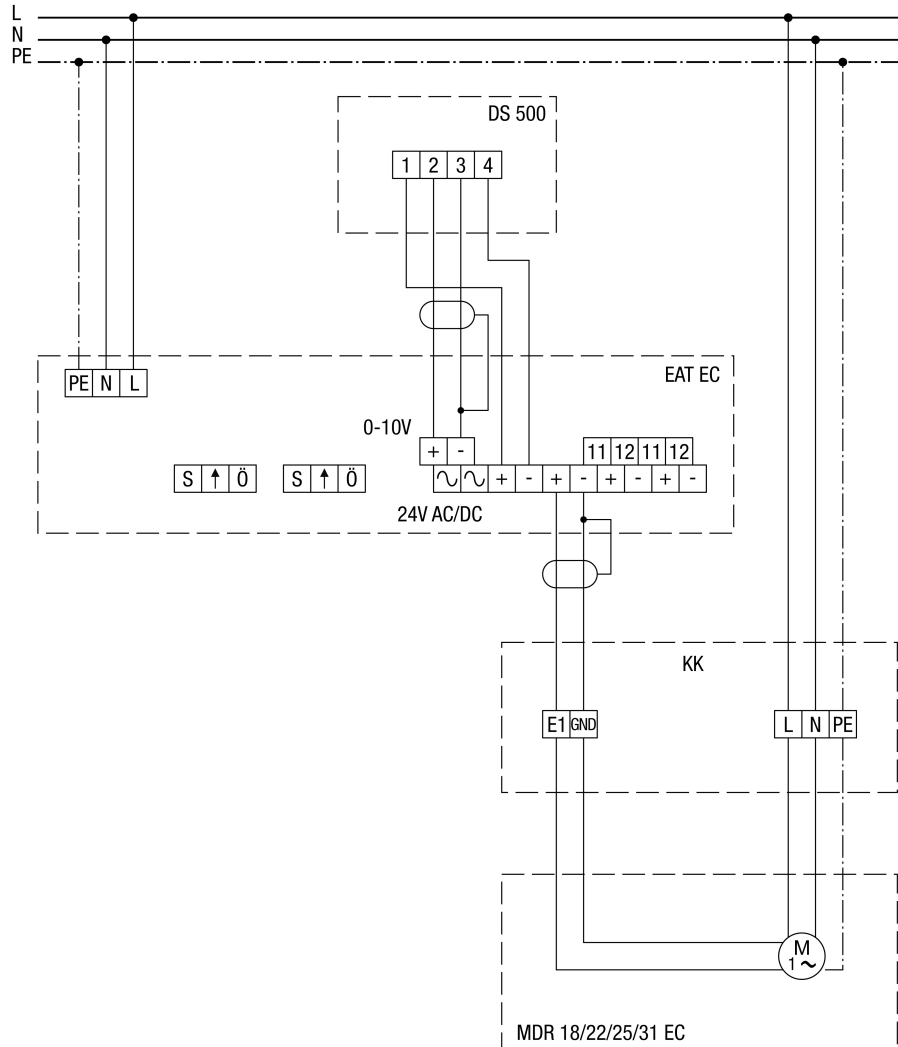

KK - terminal box