

# WIRING DIAGRAM

## geniovent.x 900 H D-G-SU



### geniovent.x circuit board connection diagram

A2 - CDV Controller

A3 - Mains connection 230V/50Hz/16A Fuse protection to be supplied by the customer

W3 - Connection duct (to be supplied by the customer) for external safety device with potential-free contact 12 V/2 A

X01 - Slot for optional EnOcean/KNX communication plug-in module

ZP1 - Expansion board ZP1 control system of supplementary heater (for units with pre- and re-heater)

# WIRING DIAGRAM

## geniovent.x 900 H D-G-SU



### geniovent.x Connection diagram for condensate pump option

A1 - Condensate pump. Optional. Connection at units with sensitive heat exchanger

A2 - CDV Controller

A3 - Mains adapter. 12 VDC power supply, motion detector optional

V/ZUL - Fan supply air

V/ABL - Fan exhaust air

KL/AL - Shutter outside air

KL/FL - Shutter outgoing air

# WIRING DIAGRAM

## geniovent.x 900 H D-G-SU



### geniovent.x Connection diagram for pre-heater, re-heater, bypass drive

- ABL - Exhaust air temperature sensor
- AL - Outside air temperature sensor
- A1 - Signal contact potential-free max. 250VAC / 30VDC, 5A ohmic. Observe configuration!
- A2 - CDV Controller
- BY - Bypass
- B1 - Bypass drive (manufacturer: Bosch)
- F - Sensor
- FL - Outgoing air temperature sensor
- H - heater
- H1 - heater 1 (pre- or re-heater). Optional
- H2 - heater 2 (re-heater). Optional
- K - Contact
- SL - Control cable
- XB\* - Plug connection only at unit variant GVX.S! 5-pin plug connection
- ZP1 - Expansion board ZP1
- ZUL - Supply air temperature sensor

# WIRING DIAGRAM

## geniovent.x 900 H D-G-SU



### geniovent.x Connection diagram for fans, control panel

A1 - Alternative use as ModBus RTU interface. Note configuration! ModBus RTU cannot be combined with RLS T1 SYS!

A2 - CDV Controller

O - Optional

SL - Control cable

SL V/ABL - Control cable for exhaust air fan

SL V/ZUL - control cable for supply air fan

ZP1 - Expansion board ZP1. Control for supplementary heat register (for units with pre- and re-heater)

# WIRING DIAGRAM

## geniovent.x 900 H D-G-SU



### geniovent.x Connection diagram CO2 and VOC sensor, break button

- A1 - Note sensor input configuration
- A2 - CDV Controller
- A3 - Internal CO2 sensor
- A4 - External CO2 sensor, optional
- A5 - External VOC sensor, optional
- A6 - Pause Switch, optional
- S - Sensor
- SL - Control cable
- SL/ÖL - Oilflex control cable

# WIRING DIAGRAM

## geniovent.x 900 H D-G-SU

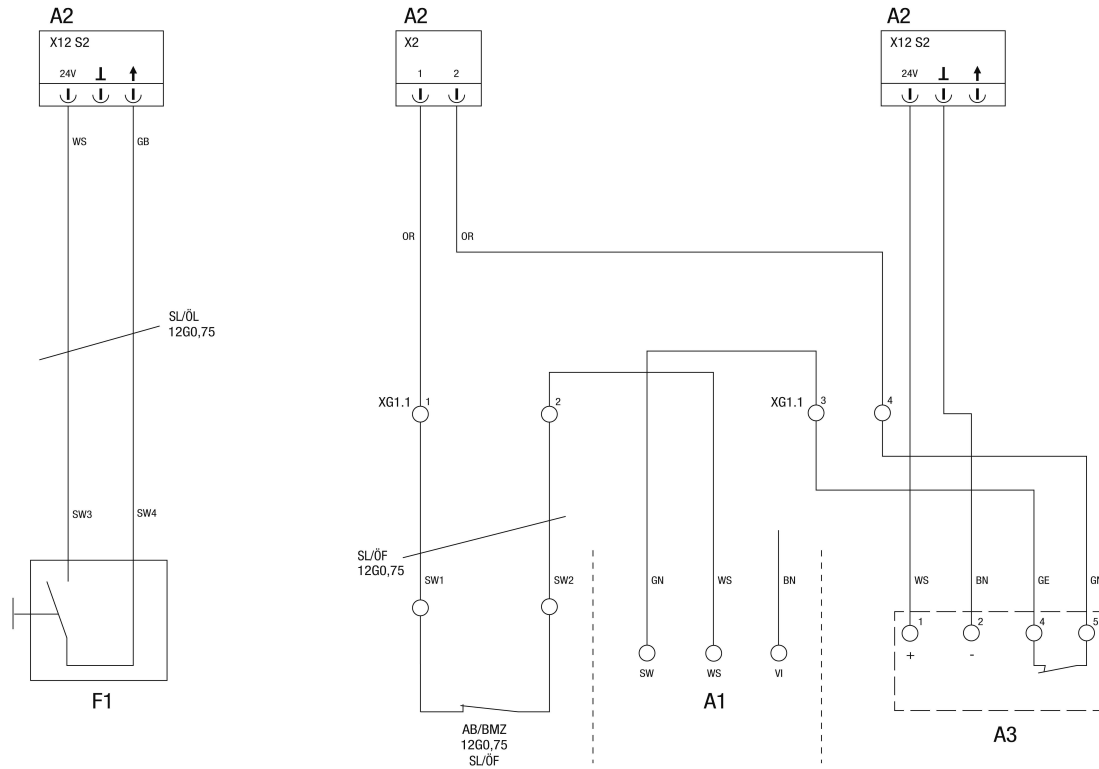

### geniovent.x Connection diagram External On/Off, BMZ switch-off, KP fault, smoke switch

A1 - Condensate pump malfunction, optional. Connection for appliances with sensitive heat exchangers

A2 - CDV Controller

A3 - Hekatron ORS 144K smoke switch, internal units optional. Power supply via terminals X12

AB/BMZ - BMZ switch-off

F1 - External on/off function, night cooling or flush mode. Release unit / function start via closed potential-free contact.

Note sensor input configuration.

S - Sensor

SL/ÖL - Oilflex control cable

# WIRING DIAGRAM

## geniovent.x 900 H D-G-SU



### geniovent.x Connection diagram for motion detector, control panel, break button, external on/off switch

A1 - Bosch ISC-BPR-W12 motion detector, optional. Power supply via 12VDC power supply unit. Note sensor input 2 configuration. For power supply connection, see page 2.

A2 - CDV Controller

BD - Control panel

F1 - External on/off function, night cooling or flush mode. Release device/function type enabled via closed potential-free contact. Note configuration of sensor input 4.

NT - Mains adapter

PT1 - Pause button optional. Connection of optional components to input. Sensors 3 and 4 only possible if control panel RB ZF 4 is not used. Note configuration of sensor input 3.

S - Sensor

SL - Control cable

SL/ÖL - Oilflex control cable

# WIRING DIAGRAM

## geniovent.x 900 H D-G-SU



**geniovent.x Connection diagram Cable connections Power supply, touch control panel RLS T1 SYS / standard control panel RB ZF 4**

- A2 - CDV Controller
- BD - Control panel
- O - Optional
- SL - Control cable
- SV - Power supply

# WIRING DIAGRAM

## geniovent.x 900 H D-G-SU



### geniovent.x Connection diagram Cable connections Optional circuits via control line / USB socket / Ethernet socket

A1 - Connection (SW3-SW9) for external sensors/contacts. For component-dependent assignment, see sheets 5, 6, 7.

Information: When connecting external sensors using wires SW3-SW9, the wires must be connected on the controller side!

A2 - CDV Controller

AS BMZ - Switch-off BMZ

ET/BU – Ethernet/RJ45 socket maico@home/BACnet TCP/ModBus TCP

ME1 - Signal contact potential-free max. 250VAC / 30VDC, 5A ohmic. Please note the configuration!

PK - Patch cable extension Cat 5

SL - Control cable

USB IS - USB / socket commissioning software

VL - Extension

