

ECR...EC

Compact Supply air unit



Made in EU



Example configuration shown

CONTENTS

1.	FOREWORD	2
2.	IMPORTANT INFORMATION	2
3.	GENERAL SAFETY INSTRUCTIONS	3
4.	ADHERE TO THE FOLLOWING INSTRUCTIONS	6
5.	PRODUCT INFORMATION	7
6.	DELIVERY CONTENTS	8
7.	TECHNICAL DATA	9
8.	DIMENSIONS	10
9.	TRANSPORT AND STORAGE	11
10.	ASSEMBLY	12
11.	ELECTRICAL CONNECTION	13
12.	COMMISSIONING	15
13.	OPERATION / SETTINGS	16
14.	MAINTENANCE AND CLEANING	27
15.	MODBUS COMMUNICATION INTERFACE	29
16.	EXPANSION AND RECONFIGURATION	38
17.	LIFETIME AND DISPOSAL	38
18.	TROUBLESHOOTING	39
19.	WIRING DIAGRAM	43

MAICO Elektroapparate-Fabrik GmbH

Steinbeisstr. 20

78056 Villingen-Schwenningen

Tel. +49 7720 694-0

Fax. +49 7720 694-263

info@maico.de

www.maico.de

The original instructions were created in the
German language.

Information updated

print 24.03.2025

Subject to change

1. FOREWORD

Dear customers,

Thank you for choosing our device.

Before operating the unit, please read carefully these installation, operating and maintenance instructions. If you have any questions, please contact: (Contact details see page 1)

The data provided in these installation, operating and maintenance instructions are for the product description only. A statement about a certain condition or a suitability for a certain application cannot be derived from our information. The information does not release the user from his own assessments and examinations.

All rights reserved by the manufacturer, even in the event of industrial property rights.

Any disposal such as copying and distribution rights lies with us.

2. IMPORTANT INFORMATION

This manual contains important information on the safe and appropriate assembly, transport, commissioning, operation, maintenance, disassembly and simple troubleshooting of the product.

The product has been manufactured according to the accepted rules of current technology.

There is, however, still a danger of personal injury or damage to equipment if the following general safety instructions and the warnings before the steps contained in these instructions are not complied with.

- Read these instructions completely and thoroughly before working with the product.
- Keep these instructions in a location where they are accessible to all users at all times.
- Always include the operating instructions when you pass the product on to third parties.

2.1. Applicable Documents

The following documents and information on the device must be observed in addition to the installation, operating and maintenance instructions:

Nameplate

Other applicable standards:

- DIN VDE 0100-100
- DIN EN 60204-1
- DIN EN ISO 13857
- DIN EN ISO 12100
- VDMA 24186-1

2.2. Provisions and regulations

When properly installed and operated, the device complies with the applicable standards and EU Directive at the time of its placing on the market.

In addition, observe generally valid, legal and other binding regulations of the European or national legislation as well as the regulations in your country for accident prevention and environmental protection.

2.3. Warranty and liability

Our devices are manufactured to the highest technical level in accordance with the generally accepted rules of technology. They are subject to constant quality controls. Because the products are being constantly developed, we reserve the right to make changes to the products at any time and without prior announcement. We assume no liability for the correctness or completeness of these installation, operating and maintenance instructions.

To ensure your warranty claims, it is imperative to provide a commissioning report and a maintenance record.

Warranty and liability claims for personal injury and property damage are excluded if they are due to one or more of the following causes:

- Improper use
- Improper mounting, commissioning, operation and maintenance
- Operating the device with defective and / or non-functional safety and protective devices
- Failure to observe the instructions regarding transportation, installation, operation and maintenance
- Unauthorized structural changes to the device
- Poor monitoring and replacement of maintenance parts
- Improperly performed repairs
- Disasters and force majeure

3. GENERAL SAFETY INSTRUCTIONS

Planners, plant engineers and operators are responsible for ensuring that the product is installed and operated correctly.

- Use our devices only in perfect technical condition.
- Check the device for obvious defects, such as cracks in the housing or missing rivets, screws, caps or other application-relevant defects.
- Only use the device in the power range specified in the technical data and on the nameplate.
- Protection against contact and being sucked in and safety distances should be provided in accordance with DIN EN 13857.
- Generally prescribed electrical and mechanical protection devices are to be provided by the client.
- The locking latch can and must only be locked or unlocked with an Allen key SW8. The latches must always be locked after closing the lids..
- Safety components must not be bypassed or put out of operation.
- The product may be operated by personnel with limited physical, sensory or mental capacities only if they are supervised or have been instructed by responsible personnel.
- Children must be kept away from the product.

3.1. Intended use

Our devices are incomplete machineries as defined in the EU Machinery Directive 2006/42/EC (partly completed machinery). The product is a not ready-for-use machine in terms of the machine directive.

It is intended exclusively for installation in a machine or in ventilation equipment and installations or for combination with other components to form a machinery or installation. The product may be commissioned only if it is integrated in the machinery/system for which it is designed and the machinery/system fully complies with the EC machinery directive.

Observe the operating conditions and performance limits specified in the technical data.

Conveying and ambient temperatures must be observed according to the technical data and the nameplate.

The units are designed for use in comfort ventilation applications.

The units must not be used for ventilation of buildings where humidity is continuously high such as swimming pools, saunas, spas.

Intended use also implies that you have fully read and understood this manual.



Improper use may result in danger to the life and limb of the user or third parties or damage to the system or other property.

3.2. Improper use

Any use of the product other than described in chapter "Intended use" is considered as improper.

The following points are improper and dangerous:

- Delivery of explosive and flammable media or operation in potentially explosive atmospheres.
- The conveyance of greasy and moist media (over 90% relative humidity).
- Delivery of aggressive and abrasive media.
- The installation in wet rooms.
- Operation without the duct system.
- Operation with closed air connections.
- The use on vehicles, aircrafts and ships.

3.3. Personnel qualifications

Assembly, commissioning, operation, disassembly and service (including maintenance and repair) require basic mechanical and electrical knowledge, as well as knowledge of the appropriate technical terms. In order to ensure operating safety, these activities may therefore only be carried out by qualified technical personnel or a person under the direction and supervision of qualified personnel. Qualified personnel are those who can recognize possible hazards and institute the appropriate safety measures due to their professional training, knowledge, and experience, as well as their understanding of the relevant conditions pertaining to the work to be done. Qualified personnel must observe the rules relevant to the subject area.

3.4. Safety instructions in this manual

In this manual, there are safety instructions before the steps whenever there is a danger of personal injury or damage to the equipment. The measures described to avoid these hazards must be observed.

Safety instructions are set out as follows:

- | | |
|--------------------------------|-----------------------------------------------------------------------------|
| Safety sign (warning triangle) | - Draws attention to the risk. |
| ● Type of risk! | - Identifies the type or source of the hazard. |
| » Consequences | - Describes what occurs when the safety instructions are not complied with. |
| → Precautions | - States how the hazard can be avoided. |

Safety sign (warning triangle)



General warning!

Indicates possible hazardous situations. Failure to observe the warnings may result in personal injury and / or damage to property.



Electricity warning (hazardous voltage)!

Indicates possible hazards due to electricity. Failure to observe the warnings may result in death, injury and/or damage to property.



Hot surface warning!

Indicates possible hazards due to high surface temperatures. Failure to observe the warnings may result in personal injury and/or damage to property.



Finger-Crushing Warning!

Indicates possible hazards due to moving and rotating parts. Failure to observe the warnings may result in personal injury.



Overhead load warning!

Indicates possible hazards due to overhead loads. Failure to observe the warnings may result in death, injury and/or damage to property.



Follow important information!

Instructions for safe, optimum use of the product.



- General warning
- » Failure to observe the warnings may result in personal injury and / or damage to property.
- Unauthorized repairs may cause personal injury and / or damage to property, in which case the manufacturer's guarantee or warranty will not apply.



- Electricity warning (hazardous voltage)!
- » Failure to observe the hazard may result in death, injury or damage to property.
- Before performing any work on conductive parts, always disconnect the unit completely from the electricity supply and make sure that it cannot be switched back on again.



- Caution! Burning hazard.
- » Failure to observe the hazard may result in personal injury and/or damage to property.
- Do not touch the surface until the motor and heater have cooled.



- Never clean the internal space with flowing water or a high-pressure cleaner. Do not use aggressive or easily flammable products for cleaning (impellers/housing).
- Only use mild soapsuds. The impeller should be cleaned with a cloth or brush.



Read the operating manual before commissioning the product.



Air filter (Panel Filter) Filter class ISO ePM10 (M5)

3.5. Safety labels on the product

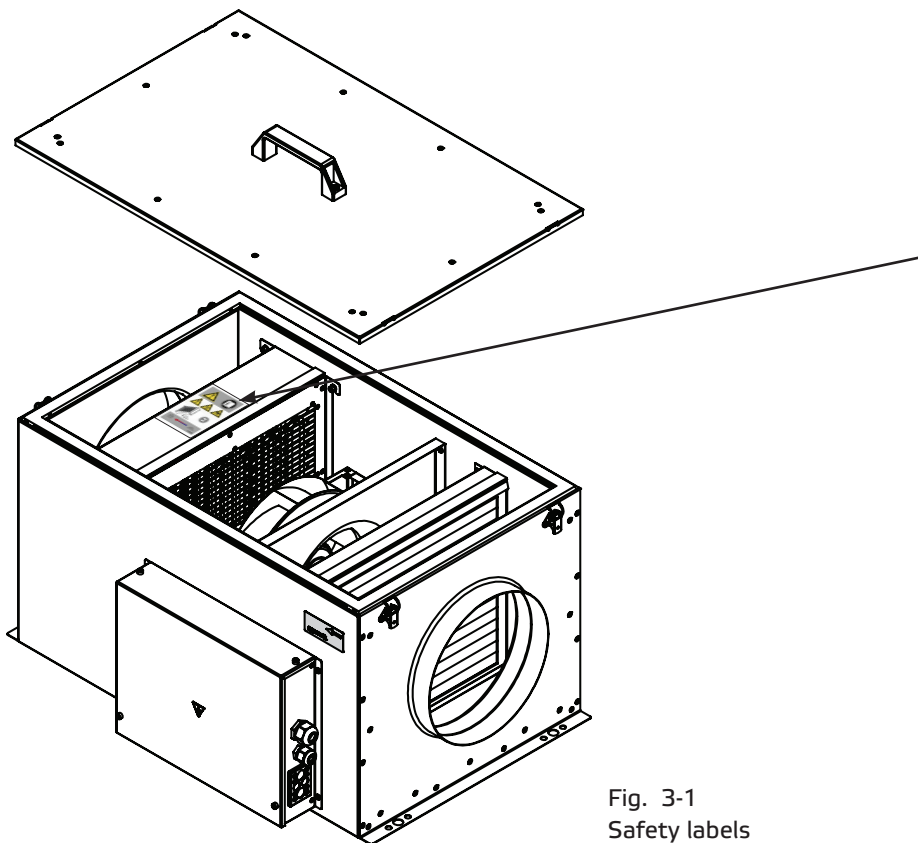

Fig. 3-1
Safety labels

4. ADHERE TO THE FOLLOWING INSTRUCTIONS

4.1. General instructions

- Persons who assemble, operate, disassemble or maintain our devices must not be under the influence of alcohol, drugs or pharmaceuticals that may affect perception and responsiveness.
- Responsibilities for the operation, maintenance and regulation of the product should be clearly determined and observed so that there can be no unclear areas of responsibility with regard to safety.

4.2. Indications assembly

- Disconnect all of the product's poles from the mains before installing the product or connecting or removing plugs. Make sure that the product cannot be switched back on again.
- Lay cables and lines so that they cannot be damaged and no one can trip over them.
- Information signs must not be changed or removed.

4.3. Indications Commissioning

- Make sure that all electrical connections are either used or covered. Commission the product only if it is installed completely.
- The power switch must always be fully functional and easy accessible!

4.4. Indications during operation

- Only authorized personnel is allowed to operate the setting mechanisms of the components or parts, under the provision that the system is used as intended.
- In an emergency, or if there is a fault, or other irregularities, switch the equipment off and make sure it cannot be switched back on again.
- The technical data given on the rating plate must not be exceeded.

5. PRODUCT INFORMATION

Description:

The FFH compact supply air unit is a complete, ready-to-use supply air unit with Z-Line air filter, fan, electric heater and integrated control. The unit has a remote control for controlling and setting up the operating parameters. The high quality housing consists of a frameless sheet metal structure with smooth internal and external walls. The housing is insulated with 30 mm mineral wool. There are no cold bridges. Glass-fibre sealed insulating material on the inside reduces intake and extraction noises.

- Galvanized steel housing.
- Removable Galvanized steel cover.
- Extractable fan unit.
- Free-running, backwards curving impeller.
- External-rotor motor with integrated thermal contact, designed for continuous operation.
- Completely integrated control.
- External control unit.
- Maximum temperature: 40 °C
- Protection class: in ceiling installation with cover at the bottom and correct duct and cable connection, IP 43 (see Wiring diagram).

5.1. Device description

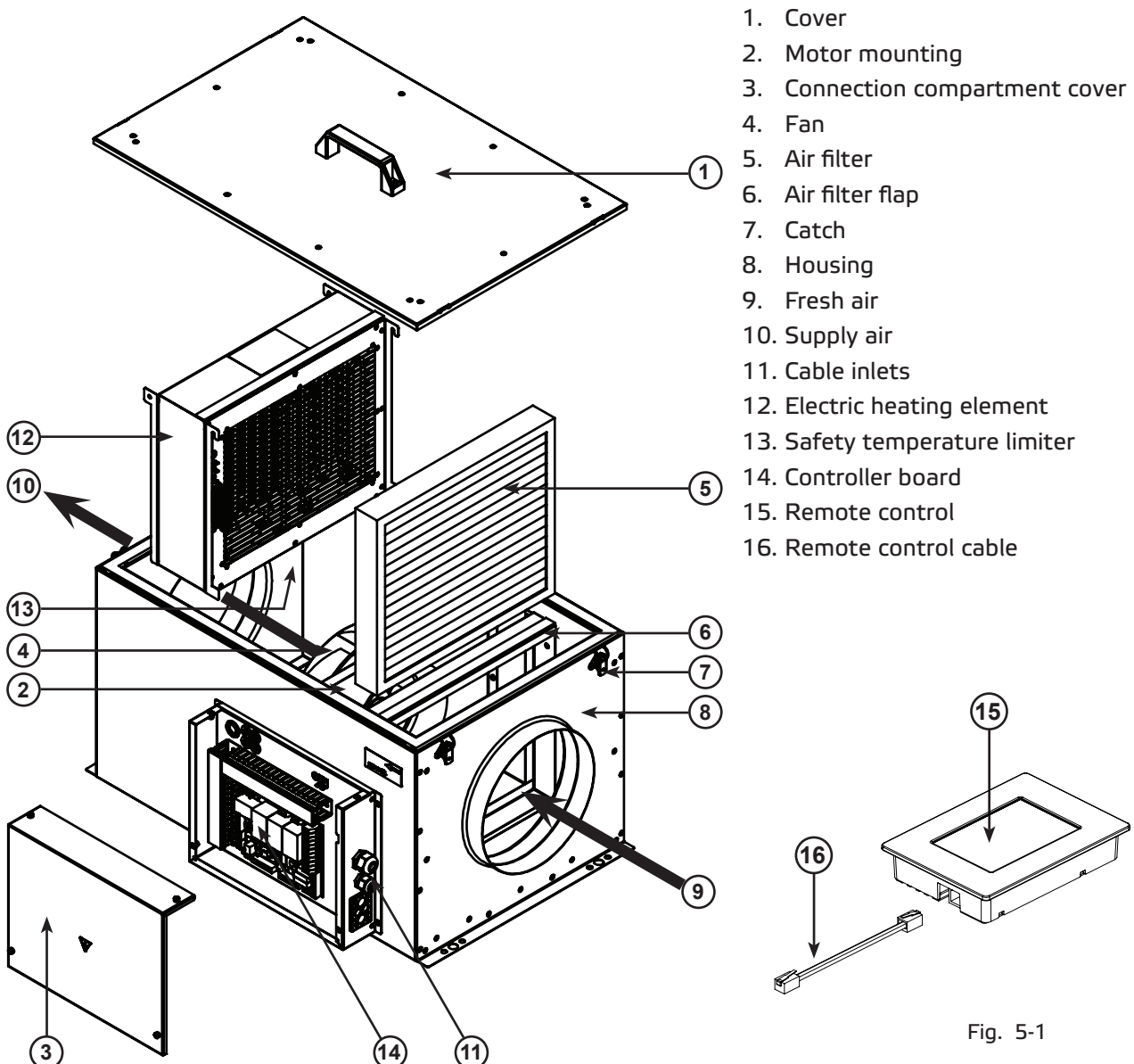
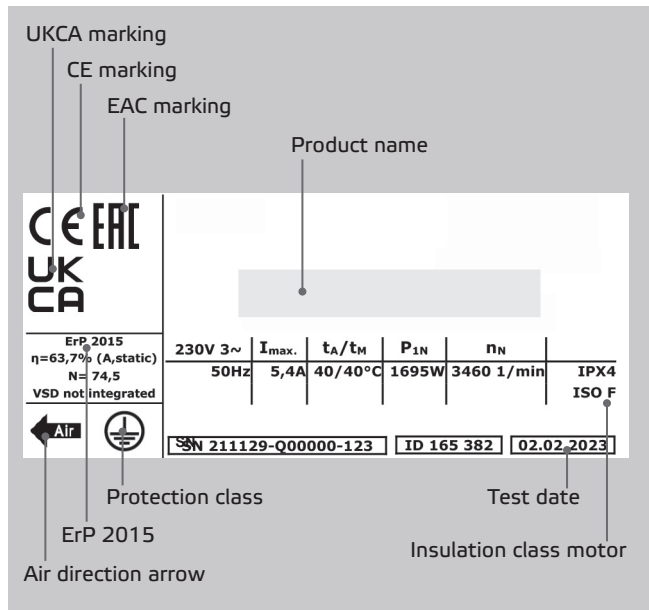

Fig. 5-1

5.2. Nameplate

ATTENTION! The information on the nameplate must always be observed!



Legend:

- I_{max} Max. current consumption
- t_A / t_M Max. ambient temperature / Max. medium temperature
- P_{1N} Rated power consumption
- n_N Rated speed

- ErP Data ErP Conformity, if required according to Reg. 327/2011
- η Overall efficiency
- N Efficiency at the optimum energy efficiency

- ID Item number
- SN Serial number

Fig. 5-2 Nameplate

6. DELIVERY CONTENTS

- 1 x FFH compact supply air unit
- 1 x remote control with control cable
- 1 x Installation, operating and maintenance instructions
- EC Declarations of conformity
- EC-Declaration of Incorporation (Directive 2006/42/EC)

7. TECHNICAL DATA

Product name		ECR 12-2 EC		ECR 16-2 EC		ECR 20-2 EC		ECR 25-2 EC		ECR 31-2 EC
Item number		173217	173219	173221	173223	173225	173227			
Voltage U_N	V	230V ~	230V ~	230V ~	400V 3~N	400V 3~N	400V 3~N			
Frequency f_N	Hz	50	50	50	50	50	50			
Rated power consumption P_N	W	3119	3119	3120	4620	9200	9200			
Max. operating current (Unit) $I_{ed, max}$	A	14,03	14,03	14,05	7,6	14,5	14,5			
Max. motor current I_{max}	A	0,98	0,98	1	0,98	1,41	1,38			
Fuse device		16A	16A	16A	3x16A	3x16A	3x16A			
Max. medium temperature t_M	°C	40	40	40	40	40	40			
Max. air volume	m ³ /h	510	605	620	660	1190	1200			
RPM	1/min	3890	3950	3940	3940	2585	2570			
Max. primary static pressure	Pa	750	750	750	750	655	660			
Sound power level supply air $L_{WA 6}$	dB(A)	71	72	73	73	69	71			
Sound power level outdoor air $L_{WA 5}$	dB(A)	67	69	69	70	71	72			
Sound power level casing $L_{WA 2}$	dB(A)	61	58	63	60	57	56			
Weight	kg	25,1	24,8	24,7	24,2	37,8	36,7			
Wiring diagrams No.										
Filter grade (Z-line)		M5	M5	M5	M5	M5	M5			

8. DIMENSIONS

ECR...EC

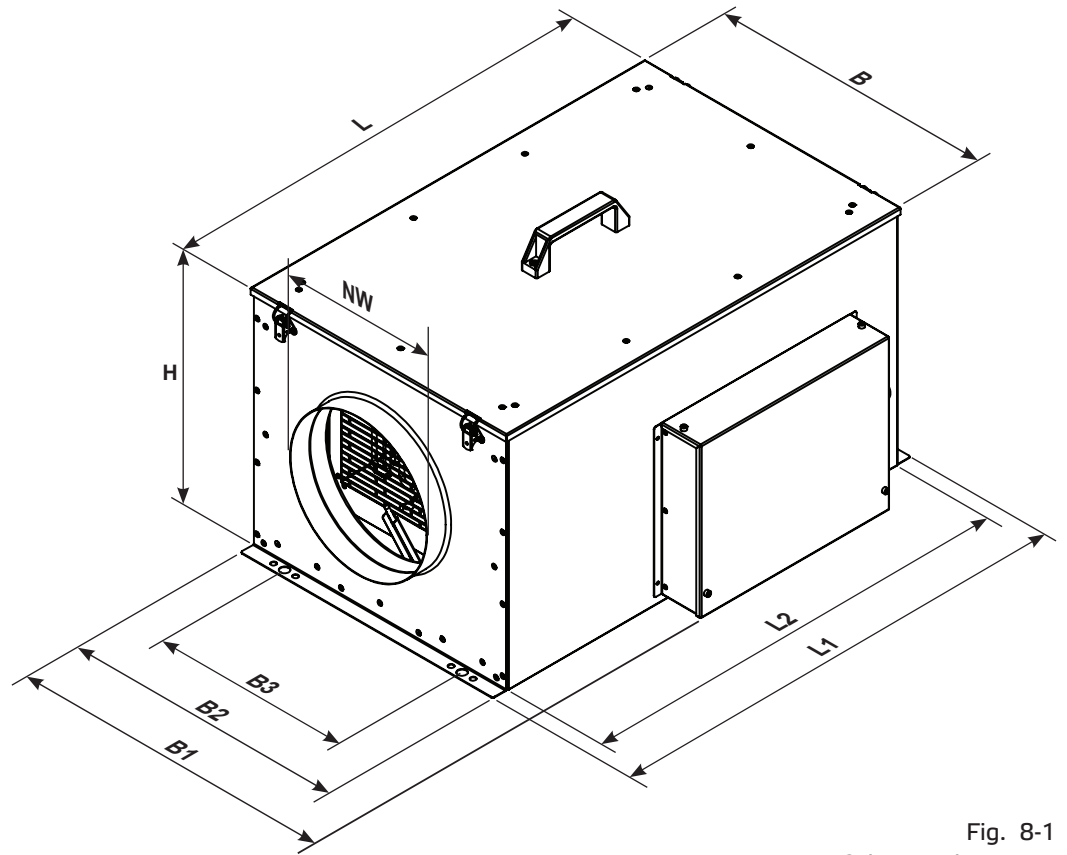

Fig. 8-1
Dimensions of the supply air unit

Product name	Item number	NW mm	L mm	L1 mm	L2 mm	B mm	B1 mm	B2 mm	B3 mm	H mm
ECR 12-2 EC	173217	125	718	760	712	406	478	399	323	346
	173219	150	718	760	712	406	478	399	323	346
ECR 16-2 EC	173221	160	718	760	712	406	478	399	323	346
ECR 20-2 EC	173223	200	718	760	712	406	478	399	323	346
ECR 25-2 EC	173225	250	718	760	712	466	538	459	323	406
ECR 31-2 EC	173227	315	718	760	712	466	538	459	323	406

8.1. Dimensions Control unit

Size	LxBxH	mm	122 x 89 x 23
Assembly size	Ø A	mm	60
	Ø D	mm	27,9

Fig. 8-2
Outside dimensions of the control unit.

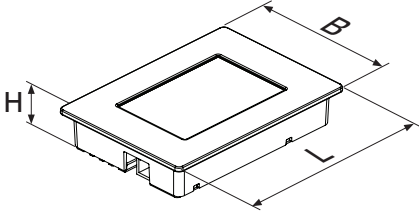
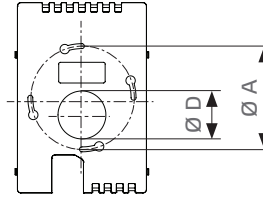

Fig. 8-3
Installation dimensions of the control unit.



9. TRANSPORT AND STORAGE

Transport and storage should only be performed by specialist personnel in accordance with the assembly and operating manual and regulations in force.

The following points should be noted and followed:

- Check the delivery according to the delivery note to ensure it is complete and correct and check for any damage. Any missing quantities or damage incurred during transport should be confirmed by the carrier. No liability is accepted if this is not observed.
- For weight see technical data
- It should be transported with suitable lifting equipment in the original packaging or on the transport equipment indicated.
- If transported with a forklift, it should be ensured that the product is resting with the basic profile or base frame completely on the forks or on a pallet and the product's centre of gravity is between the forks.
- The driver must be authorized to drive a forklift.
- Do not go beneath the suspended load.
- Never lift and transport the unit by the door handles, covers or other mounting parts!
- Avoid damage or deformation of the housing.
- The product must be stored in a dry area and protected from the weather in the original packaging. Open pallets should be covered with tarpaulins. Even weatherproof modules should be covered because their weather resistance is only guaranteed after complete installation. If moisture has penetrated into the original packaging, remove it immediately.
- Storage temperature between +5 °C and +40 °C. Avoid severe temperature fluctuations.
- If the product has been in storage for more than a year, check the smooth running of impellers and valves by hand.

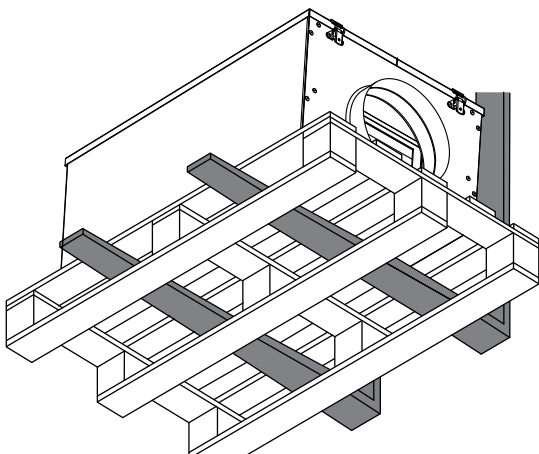

Fig. 9-1
Unit transported on a pallet with a forklift.

10. ASSEMBLY

Assembly work may only be performed by specialist personnel in accordance with the installation and operating manual and the regulations and standards in force.

The following points should be noted and followed:

- The product should only be installed on ceilings with the cover on the bottom (installation height: min 1.8 m above the ground). Alternative installation positions are given in Section 10.1 „Permitted installation positions“.
- Only install in dry rooms with no condensation.
- Installation accessories should be provided by the client.
- Only suitable installation aids, in accordance with regulations, should be used.
- The installation should be easily accessible for maintenance and cleaning and should be easy to dismantle. Leave a space of at least the height of the unit + 5 cm from other units, shelves or cabinets to facilitate maintenance work such as changing the filter (see Fig. 10-5).
- The unit should only be installed with authorized and suitable fastening materials at all fastening points.
- It must be fastened with screws or threaded rods, minimum diameter 8 mm.
- The unit should only be installed on ceilings with adequate load-bearing capacity. Wall installations are only permitted in the positions shown in Section 10.1 „Permitted installation positions“.
- Do not distort the unit when installing.
- The unit should be suitably secured.
- No holes should be made in the housing, or any screws screwed into it.
- The duct system must not be supported on the housing.
- It is recommended that the duct system is attached with flexible connections in order to isolate any structure-borne noise.
- Make sure that the duct system cannot be closed.
- Make sure that the intake duct has direct access to the intake air.
- Warning: branches in the intake duct, to other fan units for example, may, if the dimensions are too small, lead to low pressure in the duct and therefore malfunction of the unit.
- The pressure loss in the duct system must not be more than the capacity of the unit! The pressure loss in the duct should not be more than 2/3 the unit's maximum pressure so that an adequate air output can still be achieved. This will prevent malfunction.
- Pressure losses in the duct system are adversely affected by: the length of the duct system, small pipe or duct cross-section, elbows, additional filters, valves, etc.

10.1. Permitted installation positions

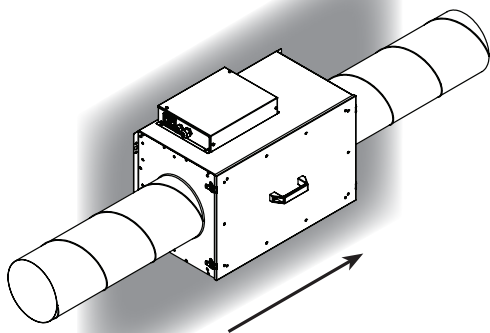

Fig. 10-1
Wall installation, connections upwards.

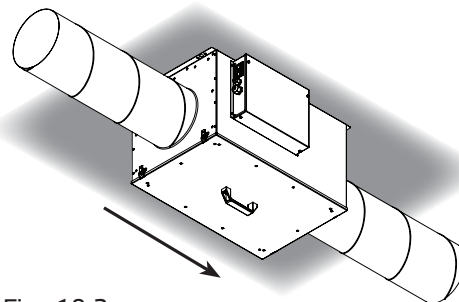

Fig. 10-2
Ceiling installation

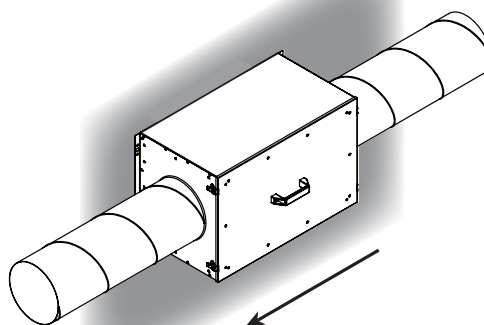

Fig. 10-3
Wall mounting connections downwards

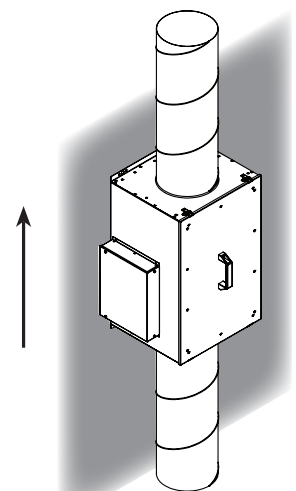

Fig. 10-4
Wall installation, air flowing upwards.

10.2. Minimum distance for maintenance works

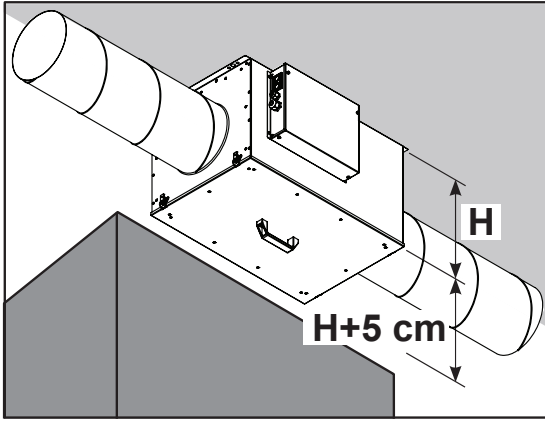

Fig. 10-5
Minimum distance for maintenance works

10.3. Operating limits

Operating limits indoor installation

Fresh air temperature -20 °C / 95% rH to +40 °C / 20% rH
Installation place: min. +5°C / 80% rH

For the ventilation of rooms where the emission sources are human metabolism or building materials and structures, e.g. offices, spaces for public service, meeting rooms as well as in rooms where smoking is allowed.

Ventilation unit not suitable for outdoor installation.

11. ELECTRICAL CONNECTION



- Electricity warning (hazardous voltage)!

- » Failure to observe the hazard may result in death, injury or damage to property.

- Before performing any work on conductive parts, always disconnect the unit completely from the electricity supply and make sure that it cannot be switched back on again.

The electrical installation may only be carried out by qualified electricians in compliance with the installation, operating and maintenance instructions and the applicable national regulations, standards and guidelines:

- ISO, DIN, EN and VDE specifications, including all safety requirements.
- Technical connection conditions.
- Safety at work and accident prevention requirements.

This list does not claim to be complete.

Requirements should be applied under one's own personal responsibility.

- The electrical connections must be made as shown in the corresponding wiring diagrams and terminal diagrams.
- The type of cable, size of cable and method of laying should be determined by an authorized electrician.
- Low and extra-low voltage cables should be laid separately.
- If no repair switch is integrated in the device, an all-pole mains disconnecting switch with min. 3 mm contact opening must be provided in the supply line.
- Use a separate cable inlet for each cable.
- Any cable inlets that are not used must be sealed so that it is airtight.
- All cable inlets must have strain relief.
- Create equipotential bonding between the unit and the duct system.
- Check all protective measures after the electrical connection work (earthing resistance, etc.)
- Motor current and motor power must not exceed the values stated on the motor nameplate. The specified max. fan speed must never be exceeded, otherwise the motor and fan will be destroyed by this overload and dissolved or flying parts can destroy other components.

Connection compartment / Connections on the unit

The connection compartment is inside the unit. You must first remove the side cover from the unit. Each lead that is connected must pass through a separate cable gland.

For this, use the supplied cable glands, fittings and cover plate. Cables that carry mains voltage must be fastened with the tension relief devices available.

Unit supply cable

Connect the mains supply cable as shown in the wiring diagram. For the dimensioning of the line, observe the unit's rating plate and the relevant guidelines. Appropriate protection with correctly dimensioned automatic safety breakers (circuit protection breaker) must be provided.

The device must be connected according to the wiring diagram.

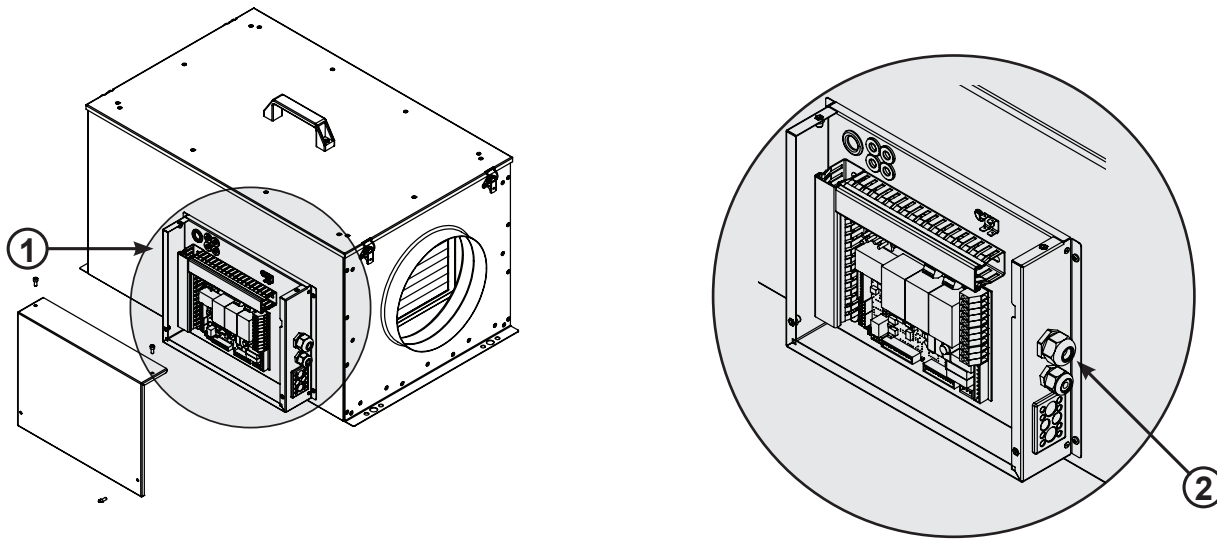

Fig. 11-1
Connection chamber (1) and cable inlets (2)



- The extra-low voltage control cables must be laid separately from the mains cables.

11.1. Overcurrent protection

- The unit may only be operated with the correct overcurrent protection.
- This must be established by a qualified electrician.
- The recommended fuse can be found in the technical data.

11.2.3. Interfaces

Control unit

The control unit is connected to the supply air unit's control system with a control cable.

A connector on the control cable is plugged directly into the socket on the control unit from beneath (see Fig. 13-1). On the unit, the control cable is first fed through a cable gland (see Fig. 11-1), placed in the cable duct and then connected to the RJ10 socket provided in the controller board. The control cable must not be shortened. Any excess length must be stowed outside of the housing. If the cable is too short, extensions can be ordered from the manufacturer or supplier. Alternatively, a 4-wire data cable with 120 Ohm resistance can also be connected. Max. cable length 100 m. This is fed through the back wall of the control unit and connected to the spring-loaded terminals. In the unit, instead of being connected to the controller board in the RJ10 socket, the cable is connected in the spring-loaded terminals next to it (see wiring diagram).

Modbus RTU

The communication interface with Modbus RTU protocol is already integrated as standard. The central building control system can be connected directly to the integrated interface via Modbus.

12. COMMISSIONING



Commissioning by trained technical personnel may only be performed after any risk has been ruled out. The following checks should be performed in accordance with the installation and operating manual and the regulations in force:

- Correctly sealed installation of the unit and duct system.
- Check the duct system, unit and medium lines, if present, remove any foreign bodies if necessary.
- The intake opening and inflow into the unit must be clear.
- Check all mechanical and electrical protection measures (e.g. earthing).
- Voltage, frequency and type of current must correspond with the rating plate.
- Check all electrical connections and wiring.
- Check any electrical, switching, safety and control devices connected.
- The unit may not be switched on when the housing is open.
- Measure electricity consumption at operating speed and compare with the rated current.
- Check the fan for excessive vibrations and noise generation.

CAUTION: Always switch off the device via the control panel or via Modbus to activate the fan run-on. Otherwise, the residual heat from the heating elements may cause malfunctions or damage to the device.

13. OPERATION / SETTINGS

13.1. Control unit

The control unit allows the selection and the command of various unit functions. A setpoint sensor for measuring the room temperature and humidity is integrated in the control panel. The display shows the various operating parameters and error messages. You can switch between displaying different menu points and make changes to your unit settings and values.

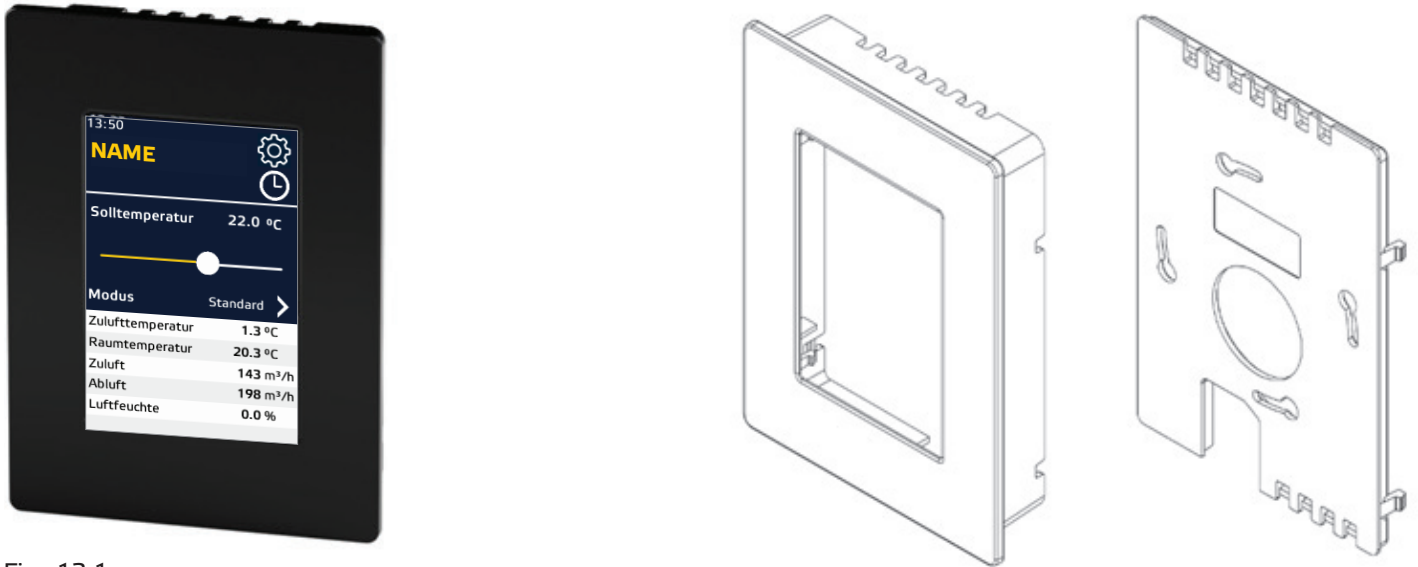

Fig. 13-1
Control unit

13.1.1. Mode selection

Flow rates, temperatures, setpoints don't need to be set separately.

Preconfigured modes (Eco, Night, Standard, Comfort, Party) with flow rates, temperatures, sensor setpoints.

In User 2 can only be selected the different modes, changes can only be made in User 3

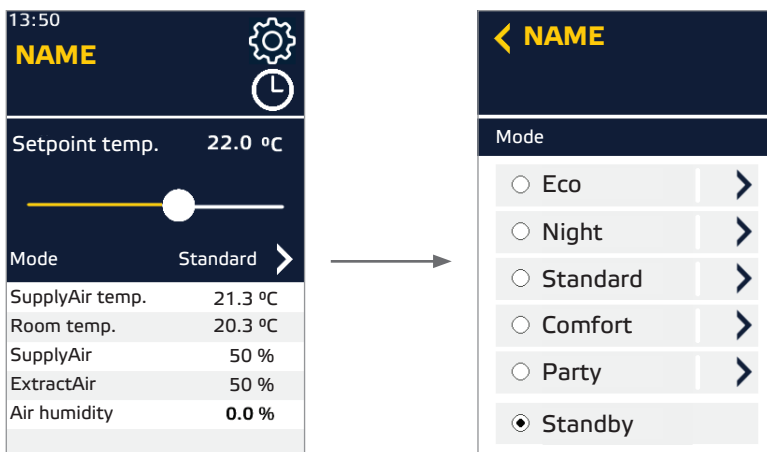

13.1.2. Adjust Modbus setpoint

The setpoints for volume flow, temperature and demand-based control (with additional sensors) stored in the respective mode as well as permissions can be set here.

Can only be changed at user level „User 3“ or higher.

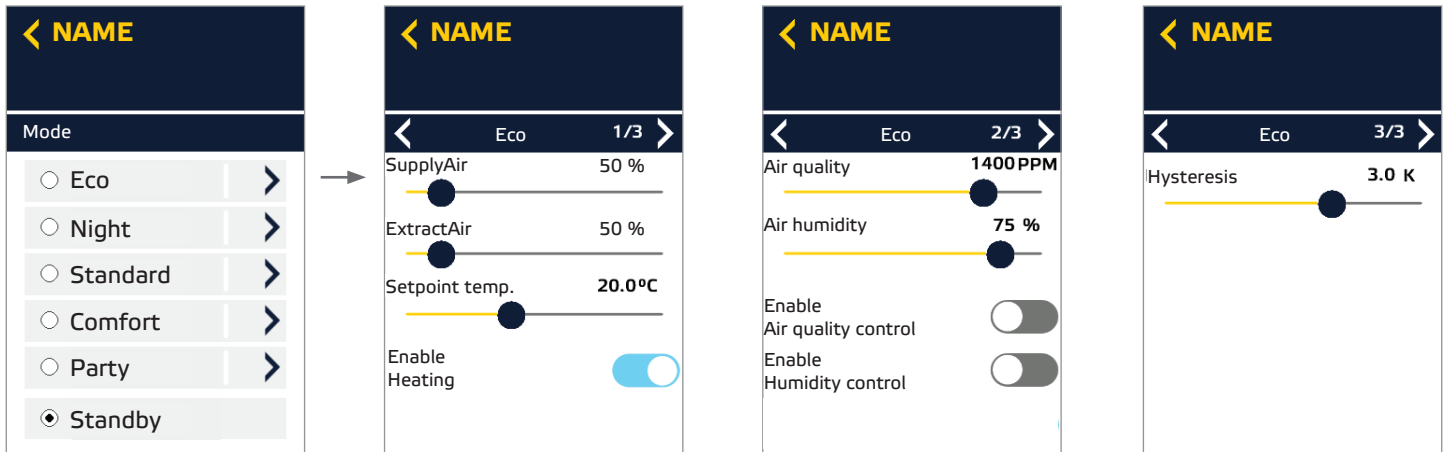

13.1.3. Main menu overview

Overview page with all relevant settings. This is opened by clicking on the cogwheel symbol.

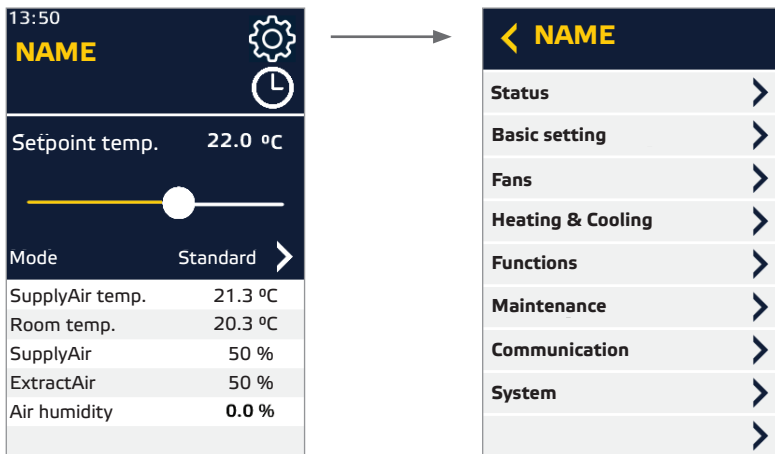

13.1.4. Status display actual values / Malfunctions

All measured values and status of the inputs/outputs can be viewed under Settings/Status.

Display of the currently measured sensor values of the ventilation unit, as well as display of faults.

Visible for all user levels.

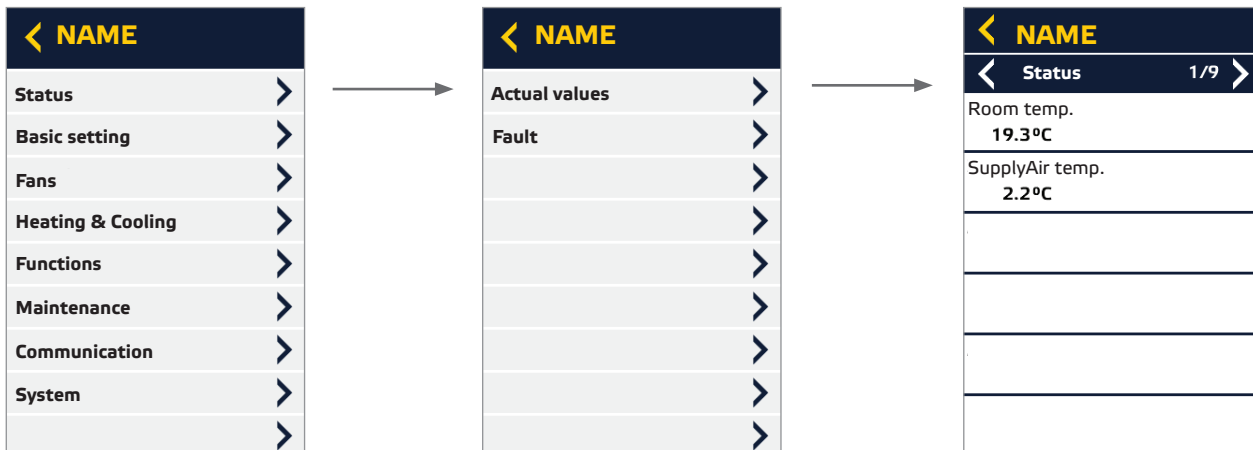

13.1.5. Basic settings

Under Settings/ Basic settings, the most important basic parameters such as unit type and minimum or maximum setpoints can be set.

Can only be changed at user level „Service“.

Individual unit parameters can only be set by the factory customer service.

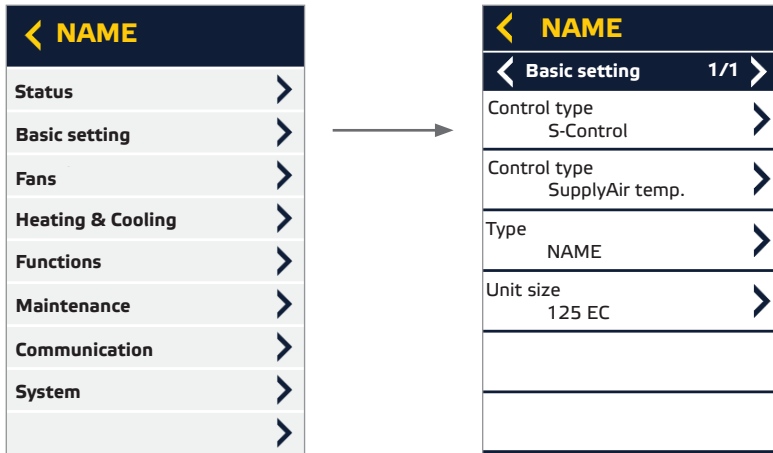

13.1.6. Fan settings

All parameters concerning the fans, such as control mode or correction factors, can be set here.

Can only be changed at user level „Service“.

Individual unit parameters can only be set by the factory customer service.



13.1.7. Heating & Cooling

Type of temperature control, heating/cooling mode and related control parameters can be set.

Can only be changed at user level „Service“.

Individual unit parameters can only be set by the factory customer service.

< NAME	< NAME	< NAME	< NAME
Status >	< Heating & Cooling 1/3 >	< Heating & Cooling 2/3 >	< Heating & Cooling 3/3 >
Basic setting >	Min. temp. 16.0°C >		P-share 10Cooling >
Fans >	Max. temp. 26.0°C >	Heating power 3 kW >	I-share 10Cooling >
Heating & Cooling >	Hysteresis Min 1.0°C >	Pressure E-heating 25 PA >	Correct. SupplyAir 0.0°C >
Functions >	Hysteresis Max 4.0°C >		
Maintenance >	Min.temp. cooling 15.0°C >	P-share 10 Heating >	Correction room 0.0°C >
Communication >	Max.temp. heating 40.0°C >	I-share 10 Heating >	
System >			

13.1.8. Functions

Under Settings/ Functions all parameters for further functionality, such as air quality control with external sensor, overrun or automatic restart are accessible.

Can only be changed at user level „Service“.

Individual unit parameters can only be set by the factory customer service.

< NAME	< NAME
Status >	< Functions 1/5 >
Basic setting >	Autorestart Off >
Fans >	Autorestart mode Mode as before >
Heating & Cooling >	Auto operation Off >
Functions >	Auto operation mode LQ-Control >
Maintenance >	
Communication >	
System >	

Autorestart:

If Autorestart is activated, the unit switches back on automatically after a voltage drop. With the selection „Autorestart Mode“ you can determine in which mode the unit starts..

Auto operation:

When Auto operation mode is activated, the unit automatically switches to Standard mode if the setpoint for the sensor set under „Auto operation mode“ is not reached.

← NAME	
← Functions	2/5 →
Night cooling Off	→
NightCool.temp. 21.0°C	→
NightCool.SupplyAir 75 %	→
NightCool.ExtractAir 75 %	→
	→
OutdoortAir sensor Off	→

Night cooling:

The night cooling function is intended to save energy in the summer months. By using the cool air during the night hours, it is possible to cool down heated rooms. If the unit is in standby mode and the night cooling function is activated, it switches on for a few minutes every hour between 00:00 and 05:00 to check whether the room can be passively cooled. If this is the case, the system runs either until the setpoint is reached in the room or until 06:00 at the latest.

← NAME	
← Functions	3/5 →
ExtractAir Qsensor Off	→
Minimum value 0V 0PPM	→
Maximum value 10V 2000PPM	→
ExtractAir rHsensor Off	→
Minimum value 0V 0%	→
Maximum value 10V 100%	→

Demand-led control according to air quality or humidity:

Activation of an air quality sensor (CO₂, VOC) or humidity sensor and setting of the measuring range. The desired setpoints can be set in each mode.

← NAME	
← Functions	4/5 →
Party input On	→
Party Input Mode Party	↘
Party Input Function Mode 1	→
Run-On time 5 min	→

Party Input:

If Party Input is activated, the unit switches to the operating mode set under „Party Input Mode“ after the external input „Motion Detector“ X21:1.2 is closed. If the contact is opened again, the unit switches back to the previously set mode after the overrun time has elapsed.

With the parameter „Party Input Function“, you can select whether the function should also be active when the system is in standby mode.

Mode 1 = Only active when the unit is already running.

Mode 2 = Additionally active when the unit is in standby mode.

← NAME	
← Functions	5/5 →
External control Off	→
	→
	→
Extern control mode Standard	→

External control:

When external control is activated, the setpoint for the volume flow is specified via an external 0-10V signal at input X21:10.11.

The parameter „External control mode“ can be used to select whether the mode can be selected manually or whether a fixed mode is always used.

13.1.9. Maintenance

All settings concerning the maintenance of the device can be made here.

Can only be changed at user level „Service“.

< NAME	
Status	>
Basic setting	>
Fans	>
Heating & Cooling	>
Functions	>
Maintenance	>
Communication	>
System	>

→

< ETA K 700	
< Maintenance 1/1 >	
Filter SupplyAir 1	>
Pressure measurement	>
FilterCal.SupplyAir1	>
Off	>
Pres.Sup.AirFilter1	>
75 PA	>
	>
	>
	>

13.1.10. Communication

Modbus communication parameters can be set here.

Can only be changed at user level „Service“.

< NAME	
Status	>
Basic setting	>
Fans	>
Heating & Cooling	>
Functions	>
Maintenance	>
Communication	>
System	>

→

< NAME	
< Communication 1/1 >	
Modbus address	>
1	>
Modbus baud rate	>
9600	>
Parity	>
NO 1 Stop Bit	>
	>
	>
	>

13.1.11. System settings

Permissions, language settings, display settings, time and unit name can be set.

Can only be changed at user level „Service“.

Individual unit parameters can only be set by the factory customer service.

< NAME	
Status	>
Basic setting	>
Fans	>
Heating & Cooling	>
Functions	>
Maintenance	>
Communication	>
System	>

→

< NAME	
< System 1/1 >	
Authorization	>
Service	>
Language	>
English	>
Display setting	>
Time	>
Device name	>
Sensor Type	>
No	>

13.1.12. User levels

Four different user levels available (default user 3).

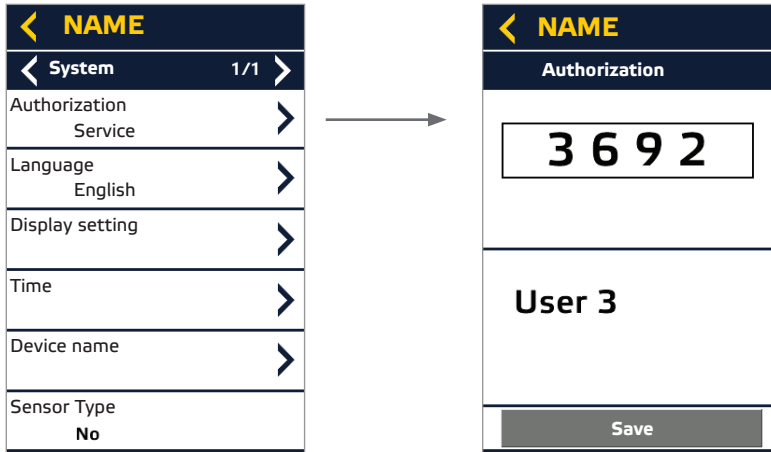

Authorization	Password	Explanation
User 1	1111 or any other number	<ul style="list-style-type: none"> ■ Settings are possible only in the timer. ■ Cannot make settings in the mode or in the settings menu. Cannot change the set mode.
User 2	2222	<ul style="list-style-type: none"> ■ Settings are possible only in the timer. ■ Cannot make settings in the mode or in the settings menu. Can change the set mode.
User 3	3692	<ul style="list-style-type: none"> ■ Can make settings in the timer and mode. ■ Can change the set mode. ■ Cannot make settings in the settings menu.
Service	4826	<ul style="list-style-type: none"> ■ Can make settings in the timer and mode. ■ Can change the set mode. ■ Can make settings in the settings menu.

13.1.13. Language selection

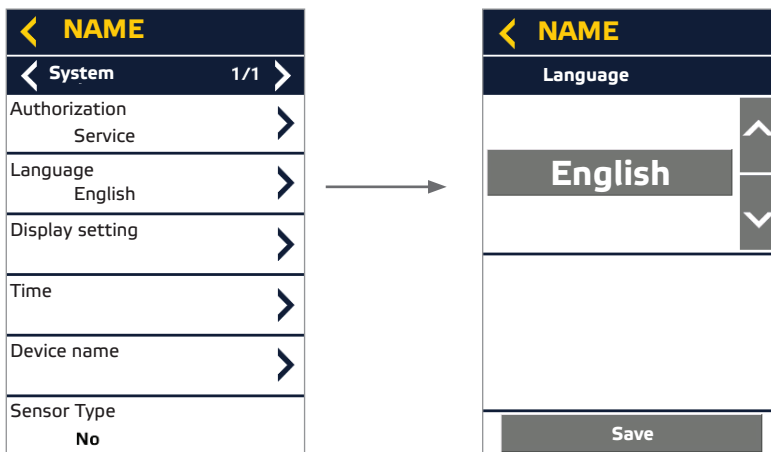

13.1.14. Display setting

Display brightness and stand-by time can be set.

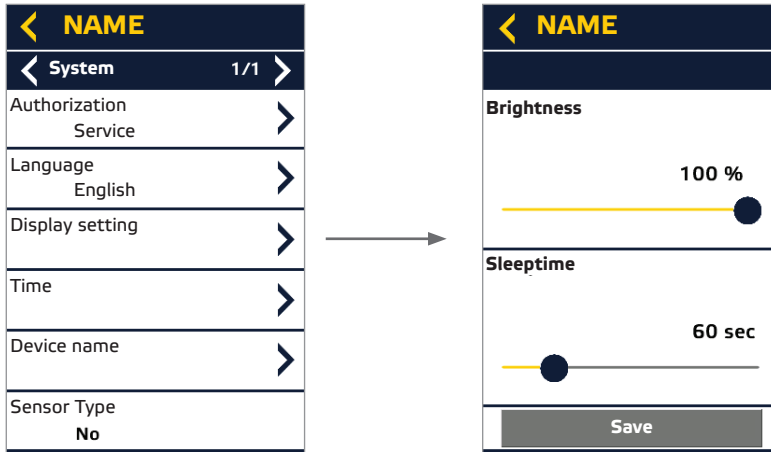

13.1.15 Device name

Device name can be set.

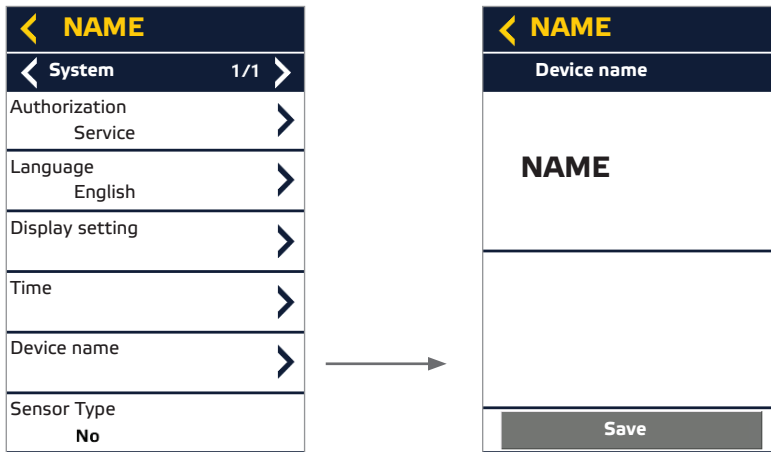

13.2. Fan control types

The fan control mode can be changed in the main menu under Basic settings. The following types of control are possible.

Constant volume flow control (S-Control)

If schedules are not used, a constant speed can be set - separately for supply and extract air. This control mode is pre-set for the unit in the delivery state.

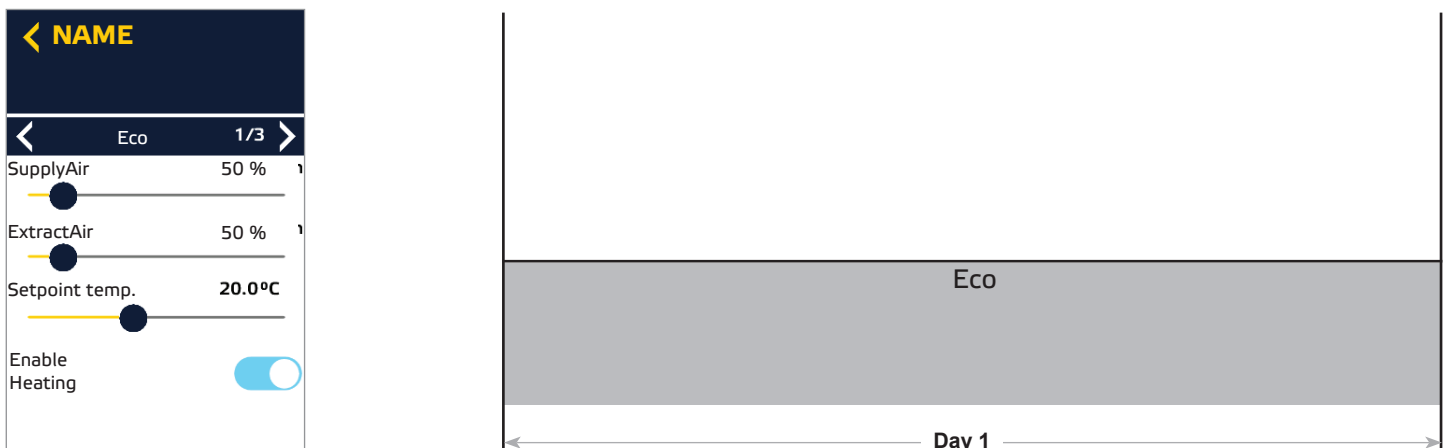

CO₂/VOC-guided air volume control

CO₂/VOC-guided air quality control is possible via a room or duct sensor with 0-10V output. If the measured CO₂/VOC content is below the setpoint, the unit runs with the minimum set air volume. If the measured CO₂/VOC content rises above the setpoint, the air volume is increased by the control system to reduce the CO₂/VOC content in the building back to the setpoint. This type of control is particularly suitable for meeting rooms, restaurants, schools and kindergartens.

Humidity-guided volume flow control

For humidity-guided control, an external humidity sensor is mounted in the extract air duct or in the room. If the measured humidity is below the setpoint, the unit runs with the minimum set air volume. If the measured humidity rises above the setpoint, the air volume is increased by the control to lower the humidity in the room back to the setpoint.

External volume flow control

With external volume flow control, the air volume is controlled by an external 0-10V signal. The preset volume flow is changed proportionally to the external signal. At 2 V control voltage, the set minimum volume flow is supplied, at 10 V the maximum volume flow. If the control voltage is less than 1.5 V, the unit is switched off.

Constant pressure control P (P-Control)

The constant pressure control P-Control is designed for operation of the ventilation unit with variable air flow rates through individual volume flow controllers. The desired pressure setpoint for supply air and extract air can be set on the control unit. Two SEN P pressure sensors are required as accessories for this operating mode. The air volume balance of the supply air and extract air strings is not balanced by the control.

Constant volume flow control (V-Control)

With this control mode, a constant volume flow can be set for the supply air.

The extract air fan is tracked and receives the same control signal as the supply air fan.

Constant volume flow control (V-Control / SUP+EXT)

With this type of control, a constant volume flow can be set separately for supply and extract air.

A pressure sensor (accessory) is required to measure the nozzle pressure on the external extract air fan. The external pressure sensor must be connected on site according to the wiring diagram (constant pressure sensor extract air). The parameter for the K value extract air fan must be set according to the K value of the external extract air fan.

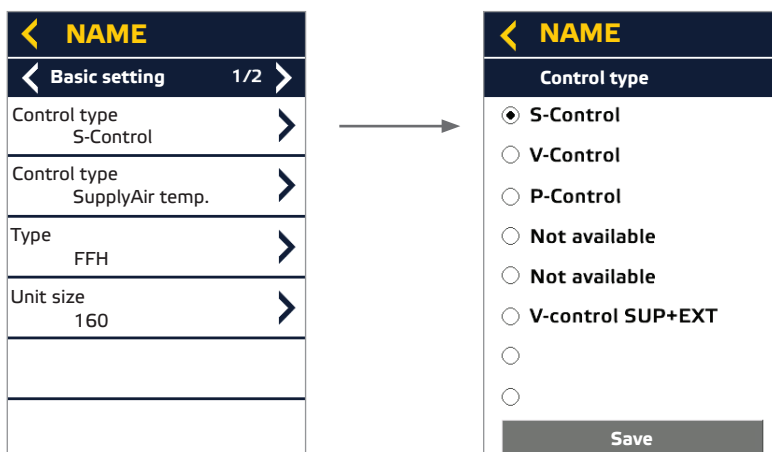

13.3. Temperature control modes (supply air or room temperature control).

The temperature measured at the sensors is compared with the setpoint temperature. The deviation between the setpoint and actual temperature causes an increased or reduced heating power. The desired control mode can be selected under Settings/Heating & Cooling.

Supply air temperature control

External heat occurring in the room is not taken into account in the supply air temperature control.

Room temperature control

External heat occurring in the room is compensated by correcting the supply air temperature. The temperature sensor is integrated in the remote control unit.

An additional room temperature sensor can optionally be connected to the appliance. See wiring diagram.

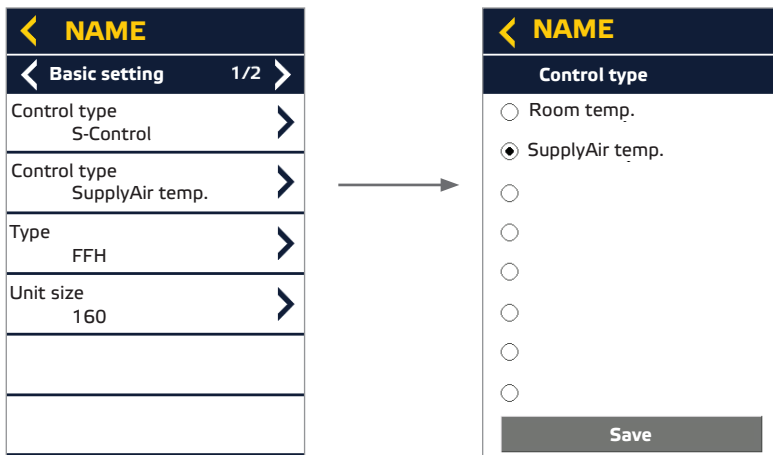

13.4. Time and schedules

The time can be set and is maintained even in the event of an interruption in the input voltage.

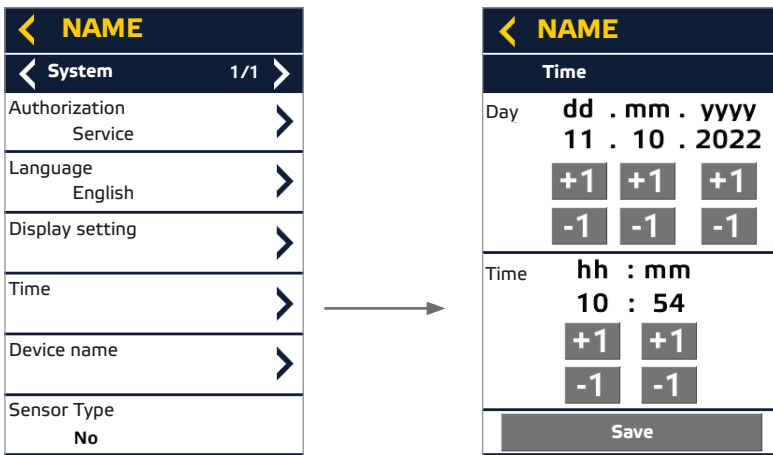

Schedules with up to 6 changes of mode per day - individually for 7 days of the week.

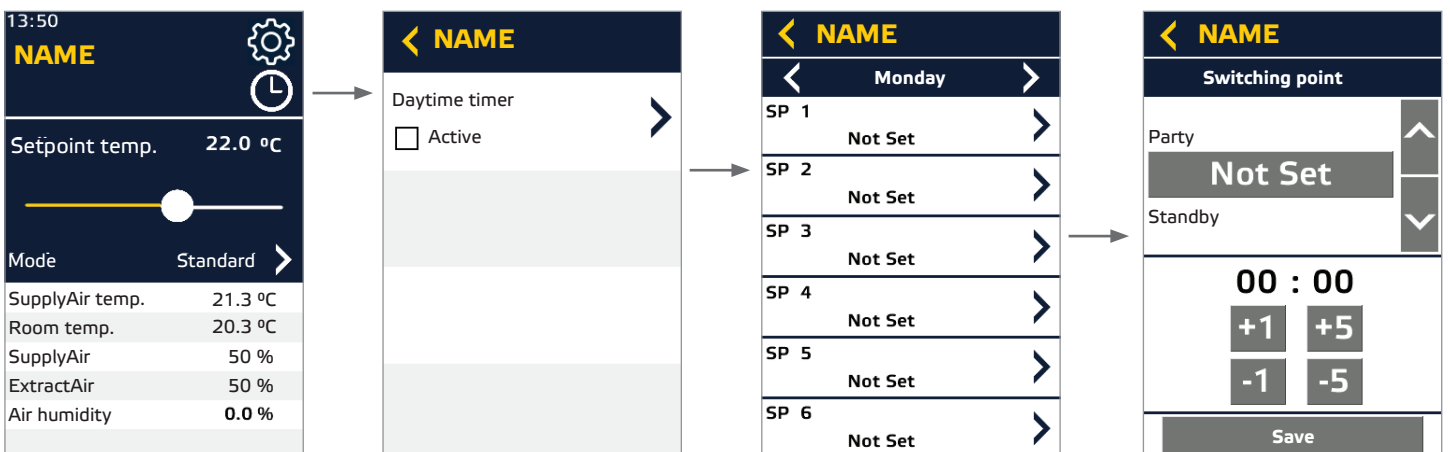

13.4.1. Switch on/off with schedule

Schedules can be used to switch the ventilation unit on and off at specific times.

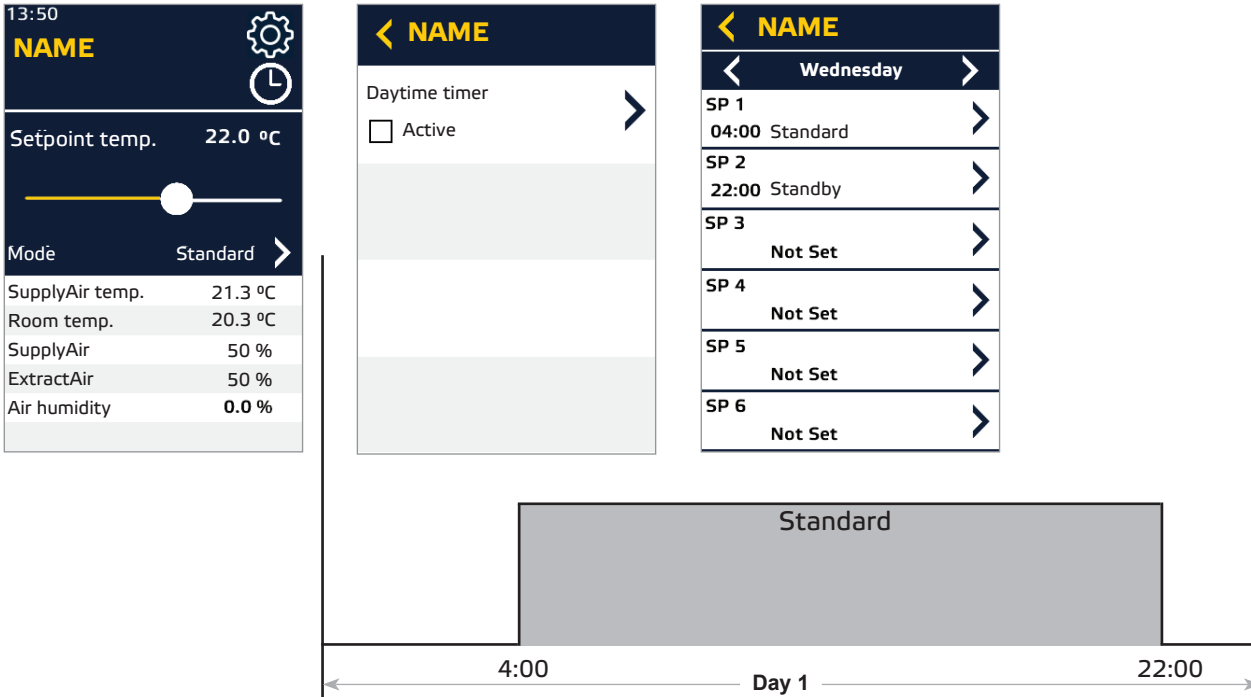

13.4.2. Night setback

For the night setback function, the „Night“ mode can be selected in the schedules. In this, the volume flow for basic ventilation is set as the default setting. The volume flows for supply air and extract air can basically be lowered or increased. In addition, the setpoint temperature can be adjusted if required. The night cooling function is particularly suitable for energy-saving operation of the ventilation unit with reduced volume flow, or for free cooling with increased volume flow in the summer months.

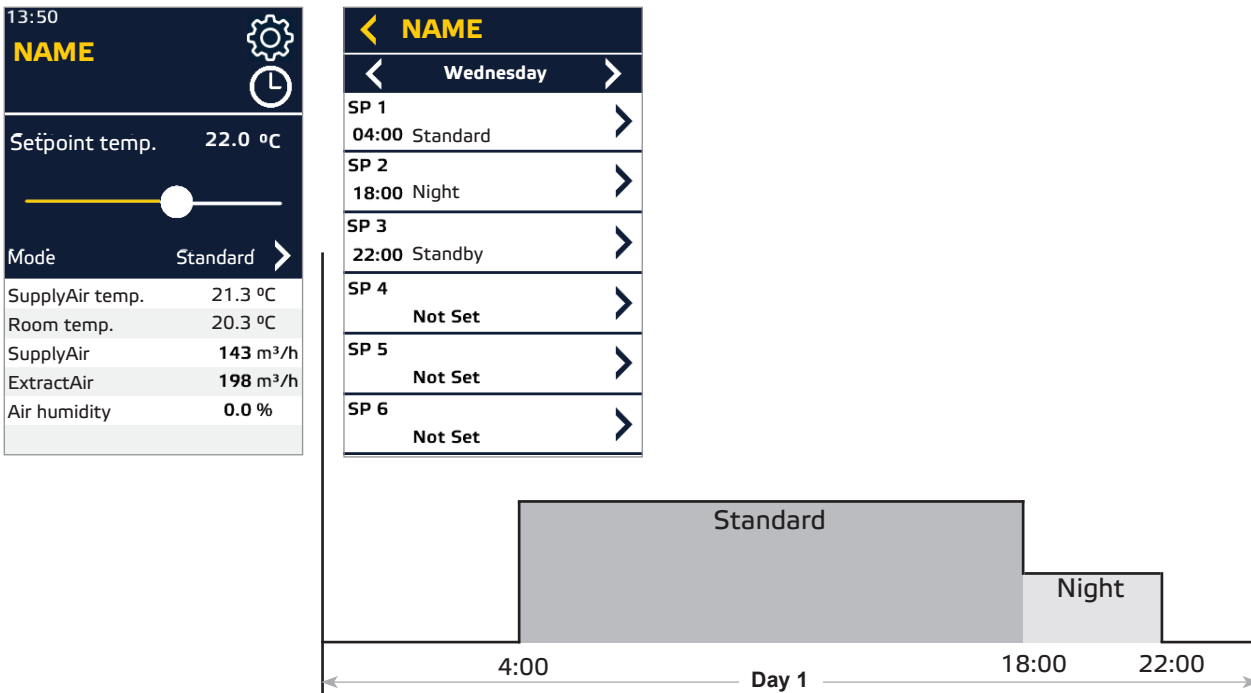

14. MAINTENANCE AND CLEANING



Servicing, troubleshooting and cleaning may only be performed by specialised personnel in accordance with this installation and operating manual and the regulations in force.



- Make sure that no connections or components are loosened unless the device is disconnected from the mains. Make sure that the equipment cannot be switched back on again.



- Individual components must not be interchanged. For example, the components intended for one product may not be used for other products.



- The regular maintenance and care of our devices is designed to ensure proper function, value retention and avoidance of damage. Keep a maintenance log.

- Perform the specified maintenance on the unit at the specified intervals.

Our devices require little maintenance when operated properly.

The following work should be performed at regular intervals, in accordance with health and safety regulations:

- Check the operation of the control system and safety devices.
- Check electrical connections and wiring for damage.
- Remove any dirt from the fan impeller or impellers and from inside the fan housing in order to prevent any unbalance or reduction in output.
 - Do not use aggressive or easily flammable products for cleaning (impellers/housing).
 - Preferably only water (not flowing water) or mild soapsuds should be used.
 - The impeller should be cleaned with a cloth or brush.
 - Never use a high-pressure cleaner.
 - Balancing clips must not be moved or removed.
 - The impeller and fittings must not be damaged in any way.
- Check the operation of the bearing with a visual inspection and by checking running noise.
- Check the unit for leaks on the air side.
- Check the correct running of the counter cross-flow heat exchanger.

Before putting the unit back into operation after maintenance and servicing work, carry out a visual inspection as described in section 11. and 12.

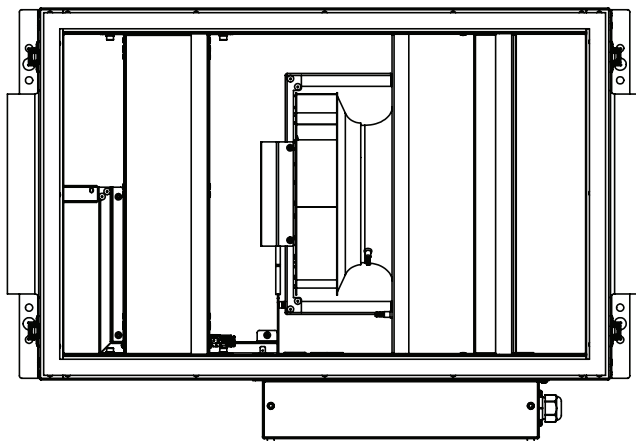

Fig. 14-1
Maintenance

14.2. Air filters

To ensure that the air filter is changed correctly, proceed as follows:

- The air filter can be removed without the use of tools.
- The air filter should be replaced if severely clogged.
- When changing the filter, make sure that the filter frame is sitting correctly on the guide rail in the device.
- Finally, the new air filter must be calibrated and the filter display reset.

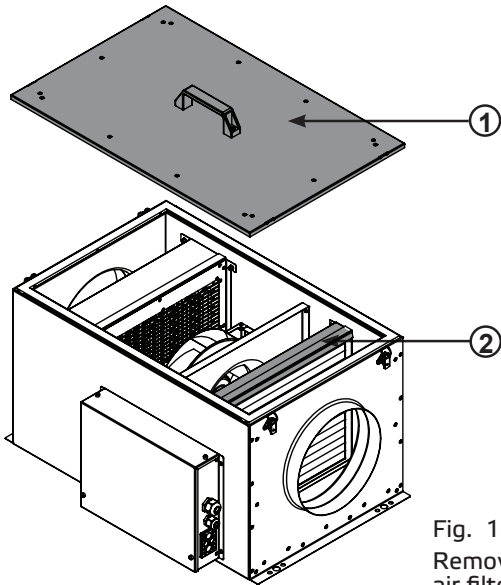

Fig. 14-2
Remove cover (1) and loosen
air filter flap (2)

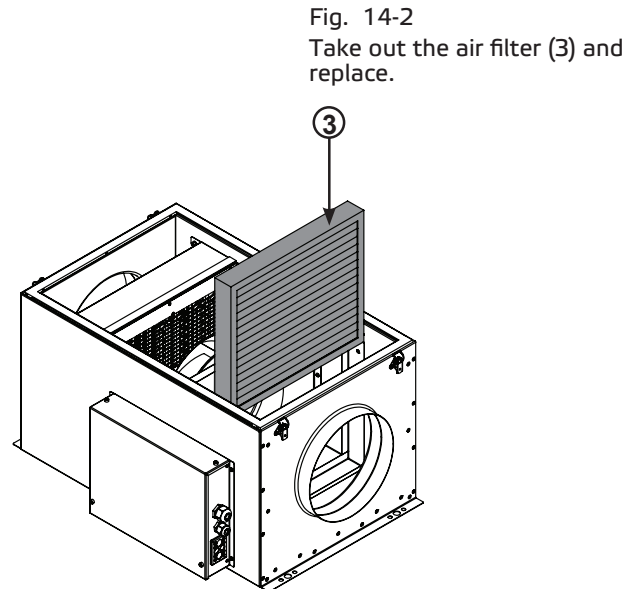

Fig. 14-2
Take out the air filter (3) and
replace.

Calibrate filter

The differential pressure increases as one of the air filters becomes more clogged. When the pressure reaches the value set on the corresponding pressure sensor, this can be seen on the status display. The filter must be changed when the level of clogging reaches 100%. The device must be recalibrated under the menu item Maintenance/ Calibrate filter.

If the filter change counter is to be incremented by one, the 'Filter change' mark must be set for the filter calibration.

Calibration is started by pressing Save after activating the 'Filter calibration' button.

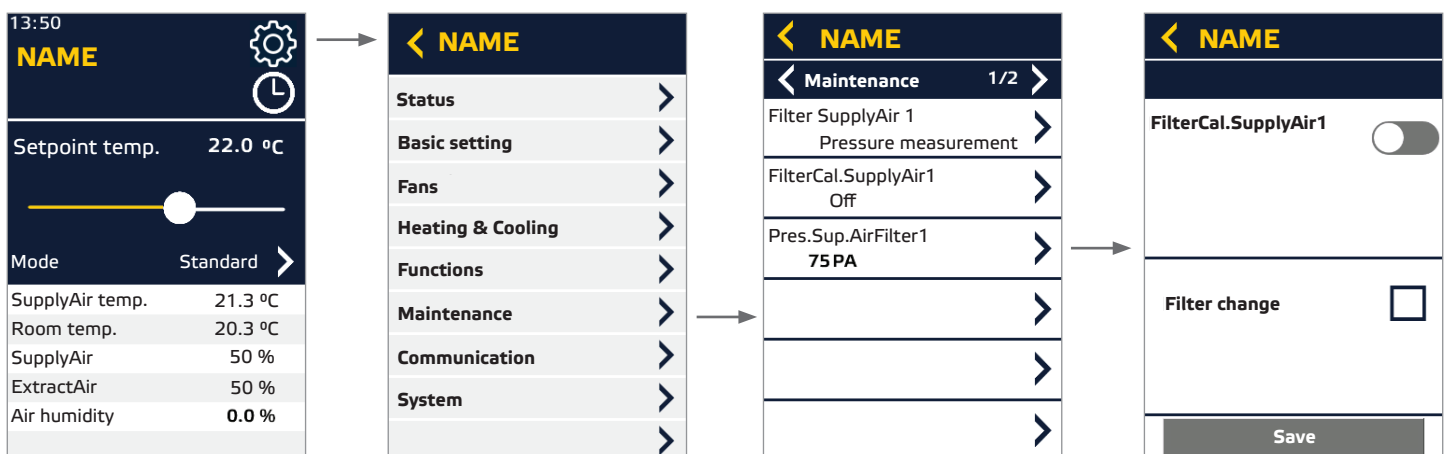

14.3. Changing the battery

Change the battery as follows:

- Remove the control cable (1) from the control unit.
- Open the control unit by removing the cover (2).
- The holder (3) for the battery is on the board. Take the battery out and replace it with a new one, as shown in the image.
- The control unit can now be closed again and the control cable connected again.
- You only have to reset the current time. The battery symbol disappears from the status display. Your control unit is fully functional again.

Note: requires a 3 V lithium CR 1220 button cell battery.

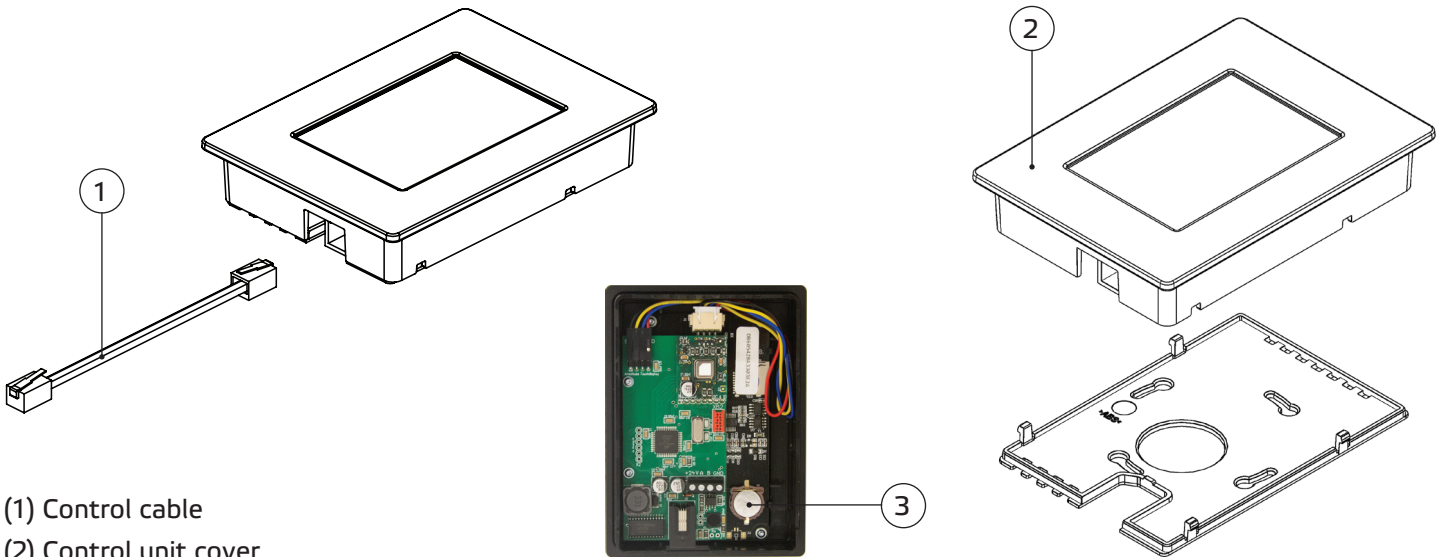

- (1) Control cable
- (2) Control unit cover
- (3) Battery holder

Fig. 14-3
Battery change remote control unit

15. MODBUS COMMUNICATION INTERFACE

15.1. Wiring diagram

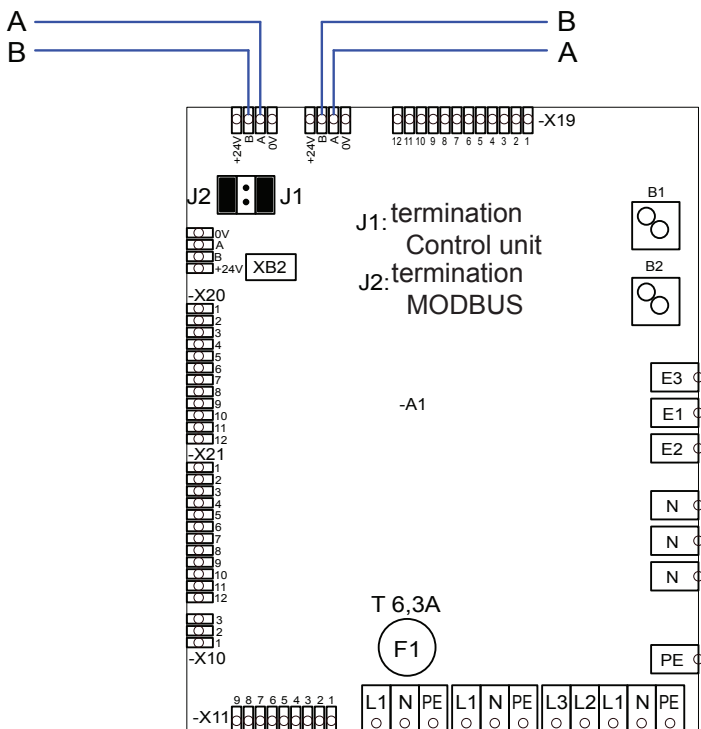

Fig. 15-1
Connection diagram ModBus

15.2. Interface information

The device works as a Modbus RTU slave. The interface configuration is 8N1, 9600Baud, slave address 1. The address and the baud rate can be set as described in the chapter „BUS Systems“. As bus line is recommended a twisted pair data cable with 120 Ohm impedance.

15.3. Functions implemented

Function code	Name	Description
03 Hex	Read Hold Register	Read device parameter
04 Hex	Read Input Register	Read current value
06 Hex	Write Single Register	Write device parameter word by word
10 Hex	Write Multiple Register	Write several device parameters word by word

Function code	Name	Sub-function	Description
08 Hex	Return Query Dat	00	Send the received message back
08 Hex	Restart Communications	01	Restart communication
08 Hex	Force Listen Only Mode	04	Switch to listen-only mode

15.4. Parameter table

Register address	Protocol address	Parameter name		Value range	Data type	Authority
40101	100	Reserved			integer	R/W
40110	109	Operating mode		0 - 5 (0 = Standby, 1 = Eco, 2 = Night, 3 = Standard, 4 = Comfort, 5 = Party)	integer	R/W
40111	110	Set-point temperature 1	Eco	Parameter 232 - 233	integer	R/W
40112	111	Set-point temperature 2	Night	Parameter 232 - 233	integer	R/W
40113	112	Set-point temperature 3	Standard	Parameter 232 - 233	integer	R/W
40114	113	Set-point temperature 4	Comfort	Parameter 232 - 233	integer	R/W
40115	114	Set-point temperature 5	Party	Parameter 232 - 233	integer	R/W
40116	115	Reserved			integer	R/W
40117	116	Hysteresis 1	Eco	Parameter 234 - 235	integer	R/W
40118	117	Hysteresis 2	Night	Parameter 234 - 235	integer	R/W
40119	118	Hysteresis 3	Standard	Parameter 234 - 235	integer	R/W
40120	119	Hysteresis 4	Comfort	Parameter 234 - 235	integer	R/W
40121	120	Hysteresis 5	Party	Parameter 234 - 235	integer	R/W
40122	121	Reserved			integer	R/W
40123	122	Set point humidity 1	Eco	40 - 80%	integer	R/W
40124	123	Set point humidity 2	Night	40 - 80%	integer	R/W
40125	124	Set point humidity 3	Standard	40 - 80%	integer	R/W
40126	125	Set point humidity 4	Comfort	40 - 80%	integer	R/W
40127	126	Set point humidity 5	Party	40 - 80%	integer	R/W
40128	127	Reserved			integer	R/W
40129	128	Target air quality 1	Eco	600 - 1600 PPM	integer	R/W
40130	129	Target air quality 2	Night	600 - 1600 PPM	integer	R/W
40131	130	Target air quality 3	Standard	600 - 1600 PPM	integer	R/W

Register address	Protocol address	Parameter name		Value range	Data type	Authority
40132	131	Target air quality 4	Comfort	600 - 1600 PPM	integer	R/W
40133	132	Target air quality 5	Party	600 - 1600 PPM	integer	R/W
40134	133	Reserved			integer	R/W
40135	134	Set point volume supply air 1	Eco	Parameter 220 - 226	integer	R/W
40136	135	Set point volume supply air 2	Night	Parameter 221 - 227	integer	R/W
40137	136	Set point volume supply air 3	Standard	Parameter 222 - 228	integer	R/W
40138	137	Set point volume supply air 4	Comfort	Parameter 223 - 229	integer	R/W
40139	138	Set point volume supply air 5	Party	Parameter 224 - 230	integer	R/W
40140	139	Reserved			integer	R/W
40141	140	Target volume extract air 1	Eco	Parameter 220 - 226	integer	R/W
40142	141	Target volume extract air 2	Night	Parameter 221 - 227	integer	R/W
40143	142	Target volume extract air 3	Standard	Parameter 222 - 228	integer	R/W
40144	143	Target volume extract air 4	Comfort	Parameter 223 - 229	integer	R/W
40145	144	Target volume extract air 5	Party	Parameter 224 - 230	integer	R/W
40146	145	Reserved			integer	R/W
40147	146	Set point pressure supply air 1	Eco	25 - 250 Pa	integer	R/W
40148	147	Set point pressure supply air 2	Night	25 - 250 Pa	integer	R/W
40149	148	Set point pressure supply air 3	Standard	25 - 250 Pa	integer	R/W
40150	149	Set point pressure supply air 4	Comfort	25 - 250 Pa	integer	R/W
40151	150	Set point pressure supply air 5	Party	25 - 250 Pa	integer	R/W
40152	151	Reserved			integer	R/W
40153	152	Set point pressure extract air 1	Eco	25 - 250 Pa	integer	R/W
40154	153	Set point pressure extract air 2	Night	25 - 250 Pa	integer	R/W
40155	154	Set point pressure extract air 3	Standard	25 - 250 Pa	integer	R/W
40156	155	Set point pressure extract air 4	Comfort	25 - 250 Pa	integer	R/W
40157	156	Set point pressure extract air 5	Party	25 - 250 Pa	integer	R/W
40158	157	Reserved			integer	R/W
40159	158	Target percent supply air 1	Eco	25 - 100%	integer	R/W
40160	159	Target percent supply air 2	Night	25 - 100%	integer	R/W
40161	160	Target percent supply air 3	Standard	25 - 100%	integer	R/W
40162	161	Target percent supply air 4	Comfort	25 - 100%	integer	R/W
40163	162	Target percent supply air 5	Party	25 - 100%	integer	R/W
40164	163	Reserved			integer	R/W
40165	164	Target percent extract air 1	Eco	25 - 100%	integer	R/W
40166	165	Target percent extract air 2	Night	25 - 100%	integer	R/W
40167	166	Target percent extract air 3	Standard	25 - 100%	integer	R/W
40168	167	Target percent extract air 4	Comfort	25 - 100%	integer	R/W
40169	168	Target percent extract air 5	Party	25 - 100%	integer	R/W
40170	169	Reserved			integer	R/W
40171	170	Enable heating 1	Eco	0 - 1 0 = OFF, 1 = ON	integer	R/W
40172	171	Enable heating 2	Night	0 - 1 0 = OFF, 1 = ON	integer	R/W
40173	172	Enable heating 3	Standard	0 - 1 0 = OFF, 1 = ON	integer	R/W
40174	173	Enable heating 4	Comfort	0 - 1 0 = OFF, 1 = ON	integer	R/W
40175	174	Enable heating 5	Party	0 - 1 0 = OFF, 1 = ON	integer	R/W
40176	175	Reserved			integer	R/W
40177	176	Enable cooling 1	Eco	0 - 1 0 = OFF, 1 = ON	integer	R/W
40178	177	Enable cooling 2	Night	0 - 1 0 = OFF, 1 = ON	integer	R/W
40179	178	Enable cooling 3	Standard	0 - 1 0 = OFF, 1 = ON	integer	R/W

Register address	Protocol address	Parameter name		Value range		Data type	Authority
40180	179	Enable cooling 4	Comfort	0 - 1	0 = OFF, 1 = ON	integer	R/W
40181	180	Enable cooling 5	Party	0 - 1	0 = OFF, 1 = ON	integer	R/W
40182	181	Reserved				integer	R/W
40189	188	Enable humidity control 1	Eco	0 - 1	0 = OFF, 1 = ON	integer	R/W
40190	189	Enable humidity control 2	Night	0 - 1	0 = OFF, 1 = ON	integer	R/W
40191	190	Enable humidity control 3	Standard	0 - 1	0 = OFF, 1 = ON	integer	R/W
40192	191	Enable humidity control 4	Comfort	0 - 1	0 = OFF, 1 = ON	integer	R/W
40193	192	Enable humidity control 5	Party	0 - 1	0 = OFF, 1 = ON	integer	R/W
40194	192	Reserved				integer	R/W
40195	194	Enable LQ control 1	Eco	0 - 1	0 = OFF, 1 = ON	integer	R/W
40196	195	Enable LQ control 2	Night	0 - 1	0 = OFF, 1 = ON	integer	R/W
40197	196	Enable LQ control 3	Standard	0 - 1	0 = OFF, 1 = ON	integer	R/W
40198	197	Enable LQ control 4	Comfort	0 - 1	0 = OFF, 1 = ON	integer	R/W
40199	198	Enable LQ control 5	Party	0 - 1	0 = OFF, 1 = ON	integer	R/W
40200	199	Reserved				integer	R/W
40214	213	Automatic restart enable		0 - 1	0 = OFF, 1 = ON	integer	R/W
40215	214	Automatic restart mode		0 - 5	(0 = Mode as before, 1 = Eco, 2 = Night, 3 = Standard, 4 = Comfort, 5 = Party)	integer	R/W
40221	220	Min volume 1	Eco	see table volumetric flow range		integer	R/W
40222	221	Min volume 2	Night		"	integer	R/W
40223	222	Min volume 3	Standard		"	integer	R/W
40224	223	Min volume 4	Comfort		"	integer	R/W
40225	224	Min volume 5	Party		"	integer	R/W
40226	225	Reserved				integer	R/W
40227	226	Max volume 1	Eco	see table volumetric flow range		integer	R/W
40228	227	Max volume 2	Night		"	integer	R/W
40229	228	Max volume 3	Standard		"	integer	R/W
40230	229	Max volume 4	Comfort		"	integer	R/W
40231	230	Max volume 5	Party		"	integer	R/W
40232	231	Reserved				integer	R/W
40233	232	Min. set point temp.		0 - 200	corresponds to 0°C - 20,0°C	integer	R/W
40234	233	Max. set point temp.		200 - 400	corresponds to 20,0°C - 40,0°C	integer	R/W
40235	234	Min. hysteresis		0 - 25	corresponds to 0°C - 2,5°C	integer	R/W
40236	235	Max. hysteresis		25 - 100	corresponds to 2,5°C - 10,0°C	integer	R/W
40237	236	Auto operation		0 - 1	0 = OFF, 1 = ON	integer	R/W
40238	237	Auto Operation Mode		see table Auto Operation Mode		integer	R/W
40239	238	external control enable		0 - 1	0 = OFF, 1 = ON	integer	R/W
40242	241	external control mode		0 - 5	(0 = Mode manually selectable, 1 = fixed Eco, 2 = fixed Night, 3 = fixed Standard, 4 = fixed Comfort, 5 = fixed Party)	integer	R/W
40243	242	LQ extract air sensor enable		0 - 1	0 = OFF, 1 = ON	integer	R/W
40244	243	Min sensor value		0 - 500 PPM		integer	R/W
40245	244	Max sensor value		2000 - 5000 PPM		integer	R/W
40251	250	Extract air humidity sensor enable		0 - 1	0 = OFF, 1 = ON	integer	R/W
40252	251	Min sensor value		0 - 20 %		integer	R/W
40253	252	Max sensor value		60 - 100 %		integer	R/W
40257	256	Calibration filter supply air 1		0 - 1	0 = OFF, 1 = ON	integer	R/W
40262	261	Δ P supply air filter 1		50 - 200 Pa		integer	R/W
40269	268	Motion detector enable		0 - 1	0 = OFF, 1 = ON	integer	R/W

Register address	Protocol address	Parameter name	Value range	Data type	Authority
40270	269	Motion detector mode	0 - 4 (0 = Eco, 1 = Night, 2 = Standard, 3 = Comfort, 4 = Party)	integer	R/W
40271	270	Motion detector functionality	0 - 1 (0 = Only active when unit is running, 1 = Always active)	integer	R/W
40272	271	Motion detector overrun time	0 - 60 min	integer	R/W
40273	272	Modbus address	1 - 240	integer	R/W
40274	273	Modbus baud rate	0 - 4 (0 = 2400, 1 = 4800, 2 = 9600, 3 = 14400, 4 = 19200)	integer	R/W
40275	274	Modbus parity	0 - 3 (0 = 8N1, 1 = 8N2, 2 = 8E1, 3 = 8O1)	integer	R/W
40276	275	Night cooling enable	0 - 1 0 = OFF, 1 = ON	integer	R/W
40279	278	Night cooling set temp	Parameter 232 - 233	integer	R/W
40282	281	Night cooling control mode	0 - 1 (0 = Room temperature control, 1 = Extract air temperature control)	integer	R/W
40284	283	Outdoor air sensor enable	0 - 1 0 = OFF, 1 = ON	integer	R/W
40290	289	Fan control type	0 - 2 (0 = S-Control, 1 = V-Control, 2 = P-control)	integer	R/W
40293	292	Fan calibration supply air	800 - 1200 corresponds to 80 - 120%	integer	R/W
40299	298	Fan calibration extract air	800 - 1200 corresponds to 80 - 120%	integer	R/W
40303	302	Temperature control mode	0 - 1 (0 = Room temperature control, 1 = Supply air temperature control)	integer	R/W
40311	310	P-share heating	5 - 20	integer	R/W
40312	311	I-share heating	5 - 20	integer	R/W
40313	312	Max temp heating	350 - 500 corresponds to 35,0°C - 50,0°C	integer	R/W
40317	316	P-share cooling	5 - 20	integer	R/W
40318	317	I-share cooling	5 - 20	integer	R/W
40319	318	Min temp cooling	0 - 200 corresponds to 0,0°C - 20,0°C	integer	R/W
40320	319	Temperature correction supply air	-50 - 50 corresponds to -5,0°C - 5,0°C	integer	R/W
40321	320	Temperature correction extract air	-50 - 50 corresponds to -5,0°C - 5,0°C	integer	R/W
40322	321	Temperature correction room air	-50 - 50 corresponds to -5,0°C - 5,0°C	integer	R/W
40323	322	Filter change supply air 1	0 - 1 0 = OFF, 1 = ON	integer	R/W
40341	340	Parameter_Save	12439 = Save parameter, value changes to 0 after saving	integer	R/W
40342	341	Control word1	32 = Clear fault, Value change after saving under 0	integer	R/W
40401	400	Set 1 SP1	0000 - 2359 corresponds to 00:00 h - 23:59 h	integer	R/W
40402	401	Set 1 SP2	"	integer	R/W
40403	402	Set 1 SP3	"	integer	R/W
40404	403	Set 1 SP4	"	integer	R/W
40405	404	Set 1 SP5	"	integer	R/W
40406	405	Set 1 SP6	"	integer	R/W
40407	406	Set 2 SP1	"	integer	R/W
40408	407	Set 2 SP2	"	integer	R/W
40409	408	Set 2 SP3	"	integer	R/W
40410	409	Set 2 SP4	"	integer	R/W
40411	410	Set 2 SP5	"	integer	R/W
40412	411	Set 2 SP6	"	integer	R/W
40413	412	Set 3 SP1	"	integer	R/W
40414	413	Set 3 SP2	"	integer	R/W
40415	414	Set 3 SP3	"	integer	R/W
40416	415	Set 3 SP4	"	integer	R/W
40417	416	Set 3 SP5	"	integer	R/W
40418	417	Set 3 SP6	"	integer	R/W

Register address	Protocol address	Parameter name	Value range	Data type	Authority
40419	418	Set 4 SP1		integer	R/W
40420	419	Set 4 SP2		integer	R/W
40421	420	Set 4 SP3		integer	R/W
40422	421	Set 4 SP4		integer	R/W
40423	422	Set 4 SP5		integer	R/W
40424	423	Set 4 SP6		integer	R/W
40425	424	Set 5 SP1		integer	R/W
40426	425	Set 5 SP2		integer	R/W
40427	426	Set 5 SP3		integer	R/W
40428	427	Set 5 SP4		integer	R/W
40429	428	Set 5 SP5		integer	R/W
40430	429	Set 5 SP6		integer	R/W
40431	430	Set 6 SP1		integer	R/W
40432	431	Set 6 SP2		integer	R/W
40433	432	Set 6 SP3		integer	R/W
40434	433	Set 6 SP4		integer	R/W
40435	434	Set 6 SP5		integer	R/W
40436	435	Set 6 SP6		integer	R/W
40437	436	Set 7 SP1		integer	R/W
40438	437	Set 7 SP2		integer	R/W
40439	438	Set 7 SP3		integer	R/W
40440	439	Set 7 SP4		integer	R/W
40441	440	Set 7 SP5		integer	R/W
40442	441	Set 7 SP6		integer	R/W
40457	456	Reserved		integer	R/W
40491	490	Day timer On Off	0 = Timer deactivated 255 = Timer activated	integer	R/W
40496	495	Save timer data	1243 = Save timer data, value changes to 0 after saving.	integer	R/W
40501	500	Set 1 Modus 1	0 - 7 (0 = Standby, 1 = Eco, 2 = Night, 3 = Standard, 4 = Comfort, 5 = Party, 6 = Reserve, 7 = Switch point not active)	integer	R/W
40502	501	Set 1 Modus 2		integer	R/W
40503	502	Set 1 Modus 3		integer	R/W
40504	503	Set 1 Modus 4		integer	R/W
40505	504	Set 1 Modus 5		integer	R/W
40506	505	Set 1 Modus 6		integer	R/W
40507	506	Set 2 Modus 1		integer	R/W
40508	507	Set 2 Modus 2		integer	R/W
40509	508	Set 2 Modus 3		integer	R/W
40510	509	Set 2 Modus 4		integer	R/W
40511	510	Set 2 Modus 5		integer	R/W
40512	511	Set 2 Modus 6		integer	R/W
40513	512	Set 3 Modus 1		integer	R/W
40514	513	Set 3 Modus 2		integer	R/W
40515	514	Set 3 Modus 3		integer	R/W
40516	515	Set 3 Modus 4		integer	R/W
40517	516	Set 3 Modus 5		integer	R/W
40518	517	Set 3 Modus 6		integer	R/W
40519	518	Set 4 Modus 1		integer	R/W

Register address	Protocol address	Parameter name	Value range	Data type	Authority
40520	519	Set 4 Modus 2	"	integer	R/W
40521	520	Set 4 Modus 3	"	integer	R/W
40522	521	Set 4 Modus 4	"	integer	R/W
40523	522	Set 4 Modus 5	"	integer	R/W
40524	523	Set 4 Modus 6	"	integer	R/W
40525	524	Set 5 Modus 1	"	integer	R/W
40526	525	Set 5 Modus 2	"	integer	R/W
40527	526	Set 5 Modus 3	"	integer	R/W
40528	527	Set 5 Modus 4	"	integer	R/W
40529	528	Set 5 Modus 5	"	integer	R/W
40530	529	Set 5 Modus 6	"	integer	R/W
40531	530	Set 6 Modus 1	"	integer	R/W
40532	531	Set 6 Modus 2	"	integer	R/W
40533	532	Set 6 Modus 3	"	integer	R/W
40534	533	Set 6 Modus 4	"	integer	R/W
40535	534	Set 6 Modus 5	"	integer	R/W
40536	535	Set 6 Modus 6	"	integer	R/W
40537	536	Set 7 Modus 1	"	integer	R/W
40538	537	Set 7 Modus 2	"	integer	R/W
40539	538	Set 7 Modus 3	"	integer	R/W
40542	539	Set 7 Modus 4	"	integer	R/W
40541	540	Set 7 Modus 5	"	integer	R/W
40542	541	Set 7 Modus 6	"	integer	R/W

15.5. Current value table

Register address	Protocol address	Parameter name	Value range	Data type	Authority
30101	100	Reserved		integer	R
30111	110	Unit identification		integer	R
30112	111	Room temperature		integer	R
30113	112	Supply-air temperature		integer	R
30114	113	Extract-air temperature		integer	R
30115	114	Exhaust-air temperature		integer	R
30116	115	Outdoor-air temperature 1		integer	R
30118	117	Pressure difference supply air filter 1		integer	R
30122	121	Pollution supply air filter 1		integer	R
30127	126	CO2 value		integer	R
30128	127	VOC value		integer	R
30129	128	Extract air humidity		integer	R
30131	130	Pressure difference supply air fan		integer	R
30132	131	Pressure difference extract air fan		integer	R
30133	132	Volume flow supply air fan		integer	R
30134	133	Volume flow extract air fan		integer	R
30135	134	Duct pressure supply air		integer	R
30136	135	Duct pressure extract air		integer	R
30137	136	Control supply air fan		integer	R
30138	137	Control extract air fan		integer	R
30139	138	Control heating		integer	R
30140	139	Cooling control		integer	R
30150	149	Inputs	see table inputs	integer	R
30151	150	Outputs	see table outputs	integer	R
30152	151	Error number	see table fault number	integer	R
30153	152	Status		integer	R
30154	153	Program version 1		integer	R
30155	154	Program version 2		integer	R
30156	155	Hours of operation		integer	R
30157	156	Filter change supply air filter 1		integer	R
30162	161	Control value External control		integer	R

Volume flow range

ECR 12-2 EC	100 - 450 m ³ /h
ECR 16-2 EC	150 - 550 m ³ /h
ECR 20-2 EC	150 - 600 m ³ /h
ECR 25-2/31-2 EC	250 - 1000 m ³ /h

Auto Operation Mode Protocol address 237

0 =	LQ-Control
1 =	RH-Control
2 =	LQ + RH-Control
3 =	LQ + RH + Temp-Control
4 =	Temp-Control
5 =	LQ + Temp-Control
6 =	RH + Temp-Control

Inputs Protocol addresses 149

1	1 = External enable
2	1 = Fault relay fans ok
4	1 = Thermal contact fan ok
8	Reserved
16	1 = Motion detector closed
32	1 = Fire detector ok
64	Reserved
128	Reserved
256	Reserved
512	Reserved
1024	Reserved
2048	1 = Night cooling active
4096	Reserved
8192	Reserved
16384	Reserved
32768	Reserved

Outputs Protocol addresses 150

1	Reserved
2	Reserved
4	Reserved
8	Reserved
16	Reserved
32	Heating circuit 1
64	Heating circuit 2
128	Heating circuit 3
256	Unit defective
512	Damper closed
1024	Damper open
2048	Reserved
4096	Reserved
8192	Reserved
16384	Reserved
32768	Reserved

Error number Protocol address 151

0	No error
1	Supply-air temperature sensor defective
2	Room-air temperature sensor defective
3	Reserved
4	Reserved
5	Reserved
6	Reserved
7	Reserved
8	Safety thermostat triggered
9	Thermal switch for ventilator triggered
10	Fan defective
11	Reserved
12	Not enabled
13	Reserved
14	Fault fire detector
15	Reserved
16	Reserved
17	Supply-air temperature too low
18	Supply-air temperature too hot
19	Reserved
20	Reserved

16. EXPANSION AND RECONFIGURATION

The unit must not be reconfigured.

The warranty only applies to the configuration delivered.

The warranty will cease to apply after any reconfiguration or expansion.

17. LIFETIME AND DISPOSAL

17.1. Product life

The motors are equipped with maintenance-free, permanently lubricated ball bearings. Under normal operating conditions, the expected lifetime is about 40,000 operating hours.

The information given here depends strongly on the respective field of application as well as the environmental conditions.

17.2. Decommissioning and disposal



When disassembling, parts under voltage are exposed, which can lead to electric shock when touched. Before disassembly, disconnect the unit from the mains and secure it against being switched on again!

Parts and components of the device that have reached their lifetime, e.g. due to wear, corrosion, mechanical stress, fatigue and/or all other, not directly recognizable effects, must be disposed of professionally and properly after disassembly in accordance with national and international laws and regulations. The same applies to excipients in use such as oils and fats or other substances. The conscious or unconscious reuse of used components such as e.g. impellers, rolling bearings, motors. etc. can lead to a risk to persons, the environment as well as machinery and equipment. The applicable local operating regulations must be observed and applied.



Old appliances and electronic components may only be dismantled by electronically trained specialists.

Proper disposal avoids negative effects on people and the environment and enables reuse of valuable raw materials with the lowest possible environmental impact.



Do not dispose of the following components with household waste!

Old appliances, wearing parts (e.g. air filters), defective components, electrical and electronic scrap, environmentally hazardous liquids/oils, etc. Dispose of them in an environmentally friendly manner and recycle them via the appropriate collection points (→ Waste Disposal Act).

1. Separate the components according to material groups.
2. Dispose of packaging materials (cardboard, filling materials, plastic) via appropriate recycling systems or recycling centers.
3. Observe the respective country-specific and local regulations.

18. TROUBLESHOOTING

Fault	Possible cause	Remedy methods
<ul style="list-style-type: none"> ■ Fan does not start 	<ul style="list-style-type: none"> ■ No power supply ■ Impeller does not rotate freely 	<ul style="list-style-type: none"> ■ Check mains supply / connections ■ Find out the causes and, if possible, remove the fault. If not possible, contact the supplier.
<ul style="list-style-type: none"> ■ Motor overheated / temperature protection is triggered 	<ul style="list-style-type: none"> ■ Fault of the ball bearings ■ Too high operating temperature ■ Air flow is too low, motor cannot cool down 	<ul style="list-style-type: none"> ■ Contact the supplier ■ Observe the data on the nameplate ■ See fault „Low air flow“
<ul style="list-style-type: none"> ■ Device too noisy / casing vibrations 	<ul style="list-style-type: none"> ■ Dirt deposits on the impeller ■ Imbalance of the impeller ■ Connection with intake or exhaust pipe / duct causes vibrations / oscillations ■ Fixing screws released ■ Fault of the ball bearings ■ Loose impeller blade 	<ul style="list-style-type: none"> ■ See chapter maintenance and cleaning ■ Contact the supplier ■ Install fan with vibration dampers ■ Tighten screws ■ Contact the supplier ■ Contact the supplier
<ul style="list-style-type: none"> ■ Low airflow 	<ul style="list-style-type: none"> ■ Impeller runs in the wrong direction (wrong air transport direction) ■ High pressure losses in the system ■ Return flaps closed or only partially open ■ Duct system clogged ■ Speed control incorrectly set / incorrectly connected 	<ul style="list-style-type: none"> ■ Note the marking on the device / nameplate. Check electrical connections ■ Improve piping configuration or select a more powerful fan ■ Check drive system / installation position of the return flap ■ Remove blockage / clean protective grille ■ Check settings / switching unit and possibly adjust / connect
<ul style="list-style-type: none"> ■ Air handling unit does not reach setpoint temperature/ Electric heating is not working 	<ul style="list-style-type: none"> ■ Incorrect setting for “Adjust Modbus setpoint” ■ “Enable heating” not activated ■ Safety temperature limiter (STB) has triggered 	<ul style="list-style-type: none"> ■ Adjust “Modbus Setpoint” ■ Activate “Enable heating” ■ see chapter “Safety temperature limiter for version with electric heating”

Please note the following instructions:

- Proceed systematically and purposefully when troubleshooting, even under time pressure.
- In the worst case, randomly and indiscriminately dismantling and changing settings may result in it no longer being possible to determine the original cause of the fault.
- Get an overview of the unit’s operation in conjunction with the overall installation.
- Try to clarify whether the unit provided the required function in the overall installation before the fault occurred.

- Try to find any changes to the overall system in which the unit is installed:
 - Have the unit’s operating conditions or operating range been changed?
- Have any changes (e.g. reconfigurations) or repairs been performed on the overall system (installation, electrics, control) or to the unit? If yes: what?
 - Has the unit been operated correctly?
 - How does the fault appear?
- Form a clear idea of the cause of the fault. If necessary, question the immediate operator or the installation operator.

If you have not been able to remove the fault, please contact the manufacturer. The contact address can be found on the back of these installation, operating and maintenance instructions.

18.1. Low-current fuses

There is one low-current fuse built-in at the controller circuit board to protect the electrical equipment. If the fuse blows, the fault can be located and repaired by using the following table. A low-current fuse must be changed by specialised personnel.

The low-current fuses must comply with EN 60127, dimensions 5 x 20 mm.

Fuse	Possible cause	Fault correction
F1 / T 6,3 A	<ul style="list-style-type: none"> ■ Damper drive or lead defect. ■ Damper drive and cable defect. 	<ul style="list-style-type: none"> ■ Replace lead. ■ Replace damper drive and cable.

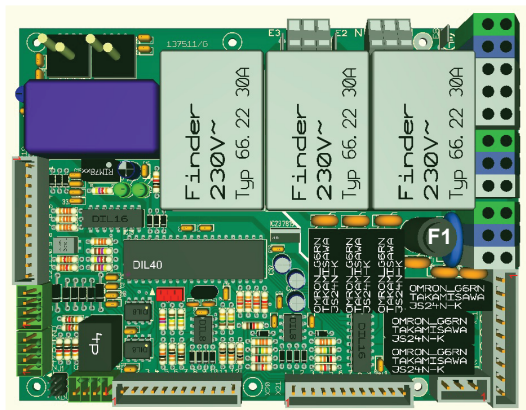
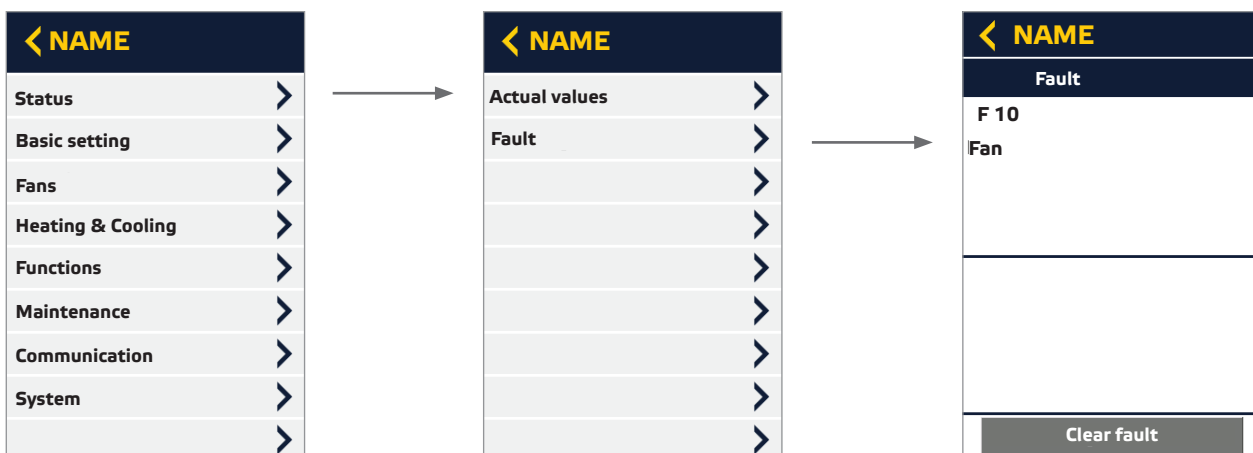

Fig. 18-1 Board with low-current fuses F1.

18.2. Fault diagnosis chart

If a fault occurs on the unit, one or more fault messages will appear on the display. The error is acknowledged with the „OK“ button. It is not possible to use the control unit until all of the faults have been removed and acknowledged. Depending on the priority of the fault, the installation will either switch off or continue working with the last settings.

The following faults might be shown on the display:



Error message	Type of fault and repair
---------------	--------------------------

	<p>ERROR</p> <ul style="list-style-type: none"> » The control unit has no connection. » Check the connection or replace the cable if necessary.
F 1	<p>Supply air temperature sensor fault</p> <ul style="list-style-type: none"> » The supply air temperature sensor is defective or the cable is broken. » Replace the defective temperature sensor or replace the broken cable if necessary. » After the failure reason is remedied, the failure must be confirmed with „OK“.
F 2	<p>Room temperature sensor fault.</p> <ul style="list-style-type: none"> » The room temperature sensor malfunctions. » Replace the remote control unit. » After the failure reason is remedied, the failure must be confirmed with „OK“.
F 8	<p>Fault in the safety thermostat - electric heating element temperature monitoring</p> <ul style="list-style-type: none"> » The housing temperature is higher than 75 °C. The control circuit is broken, the electric heater is switched off. Possible cause: defective supply air valve, fan has failed, etc. » Repair supply air valve, check fuses F2. » After the failure reason is remedied, the reset button of the safety thermostat has to be reset manually, and the failure has to be confirmed at the control unit with „OK“.
F 9	<p>Fault, fan thermal contact</p> <ul style="list-style-type: none"> » The thermal contact has been tripped, device will be switched off. Possible cause: motor overheating or defective. (X9: 6,7,8,9) » The power supply must be switched off at the main switch for at least 20 s. Check fuse F2, replace the motor if necessary. » After the failure reason is remedied, the failure must be confirmed with „OK“.
F 10	<p>Error fan</p> <ul style="list-style-type: none"> » Error monitoring of a fan has been triggered. » Switch the unit off, check wiring and fans and if needed, replace damaged fan. » After the failure reason is remedied, the failure must be confirmed with „OK“.
F 14	<p>Fire protection signal</p> <ul style="list-style-type: none"> » The fire protection contact is open. The fire detector has tripped. » After the fire detection has been remedied, you have to confirm with „OK“.
F 17	<p>Insufficient temperature of supply air</p> <ul style="list-style-type: none"> » The maximum set supply air temperature (12 °C) was undershot longer than 30 minutes. » After the failure reason is remedied, the failure must be confirmed with „OK“.
F 18	<p>Excess temperature, supply air</p> <ul style="list-style-type: none"> » The maximum supply air temperature of 80 °C was exceeded longer than 10 sec. or the cable of the air supply temperature sensor is broken. » Switch off the device, check fans. » After the failure reason is remedied, the failure must be confirmed with „OK“.
	<p>No release</p> <ul style="list-style-type: none"> » The release contact is not closed. » Close the release contact. The unit can then be started.
	<p>Device is off and cannot be switched on</p> <ul style="list-style-type: none"> » SENSORTYP stands at EXT. REG. (external controls) » Check the setting SENSOR TYPE in the operating parameters.

18.3. Safety temperature limiter for types with electrical heating coil



- Electricity warning (hazardous voltage)!

» Failure to observe the hazard may result in death, injury or damage to property.

→ Before performing any work on conductive parts, always disconnect the unit completely from the electricity supply and make sure that it cannot be switched back on again.

The electric heating element has continuous output control. A safety temperature limiter (STB) switches the electric heater off, in the event of a fault, when the temperature reaches 75 °C. Once the safety temperature limiter (depending on model with 2 or 3 limiters) has been tripped, it has to be reset manually. Before resetting the temperature limiters and reinstalling the inserts the cause for tripping of the STB needs a troubleshooting.

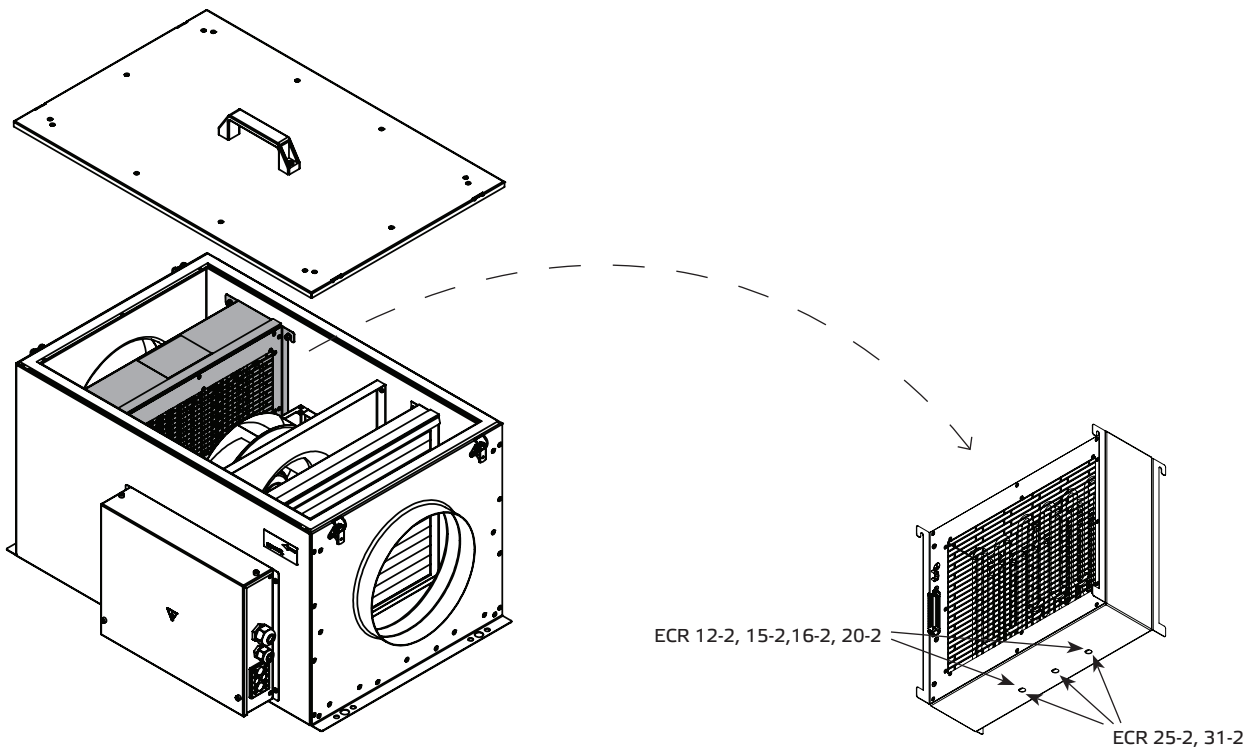

Fig. 13-3
Reset buttons safety temperature limiter



CAUTION: Tripping of the STL indicates no direct error message. (Possibly in conjunction with error F18.)

Possible cause for tripping of the STL:

- Regulation fault
- Relay fault
- Supply air fan failure
- Air duct is blocked

19. WIRING DIAGRAM

19.1. Wiring diagram 171637

ECR 12-2 / ECR 15-2 / ECR 16-2

- Netzspannung : 230V / 1~ / N / 50Hz
- Mains voltage
- Leistung : 3kW
- Power
- Vorsicherung : 1 x 16A
- Fuse

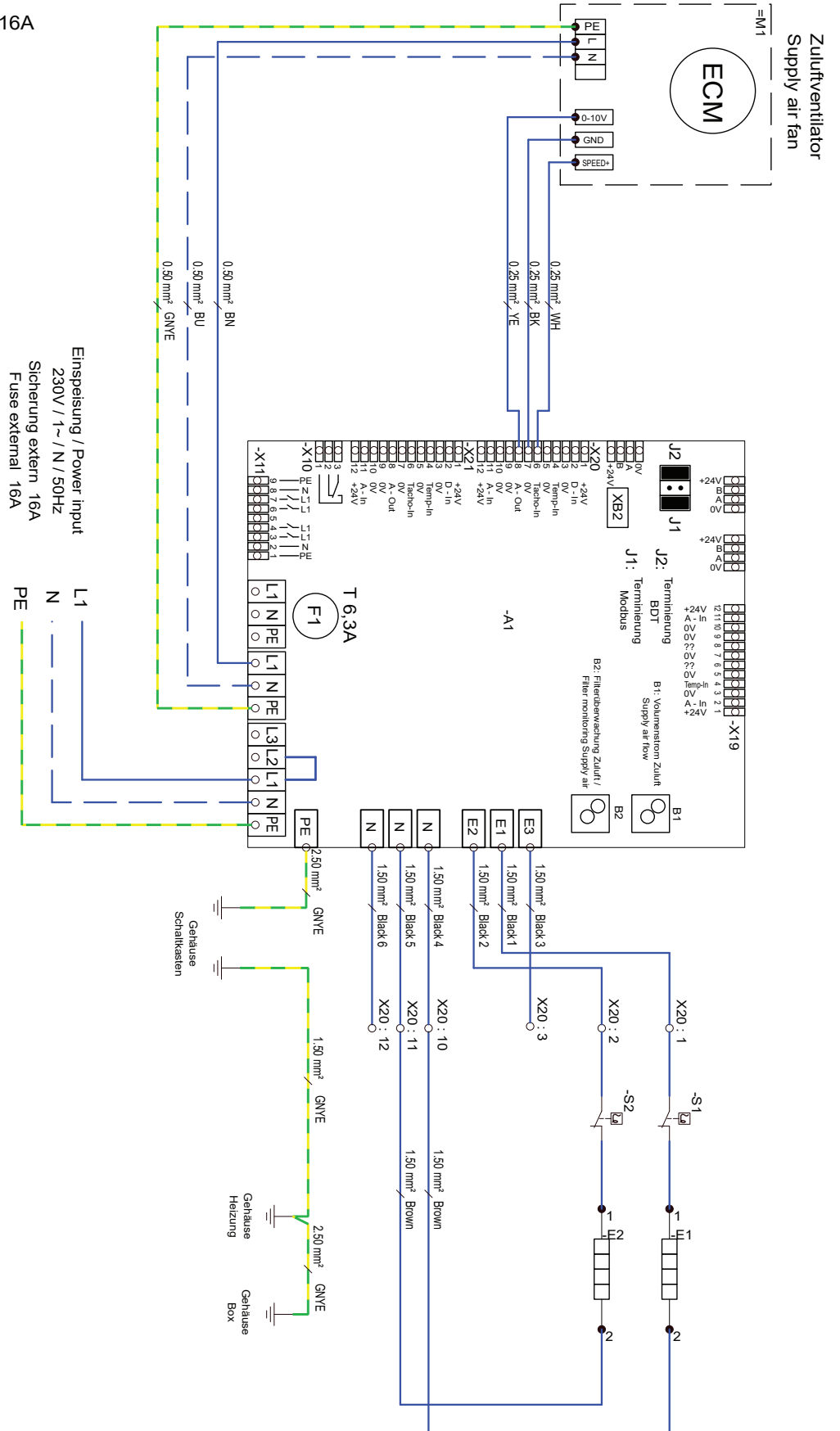

19.2. Wiring diagram 171637

ECR 20-2

Netzspannung : 400V / 3~ / N / 50Hz
 Mains voltage
 Leistung : 4,5kW
 Power
 Vorsicherung : 3 x 16A
 Fuse

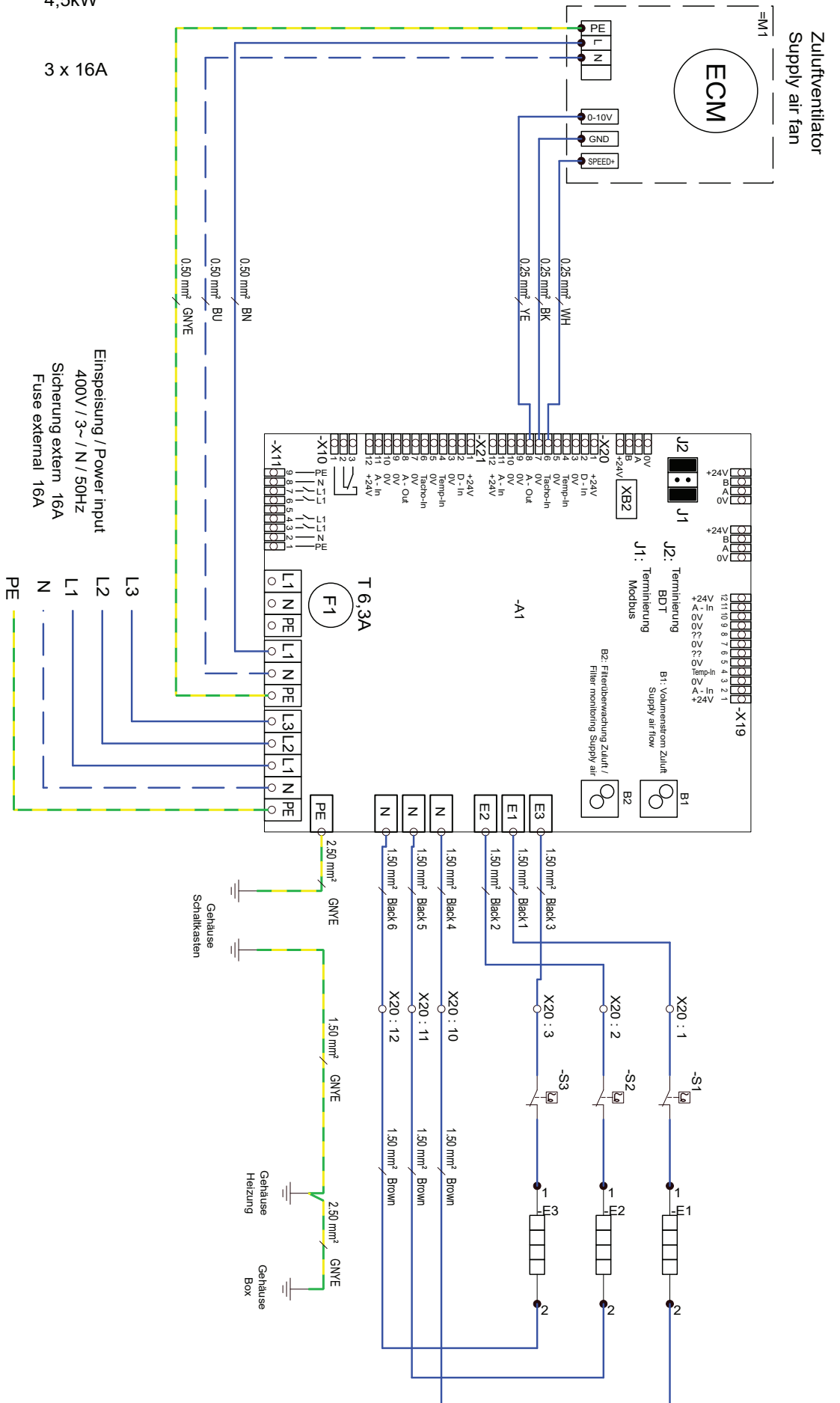

19.3. Wiring diagram 171637

ECR 25-2 / ECR 31-2

Netzspannung : 400V / 3~ / N / 50Hz
 Mains voltage

Leistung : 9kW
 Power

Vorsicherung : 3 x 16A
 Fuse

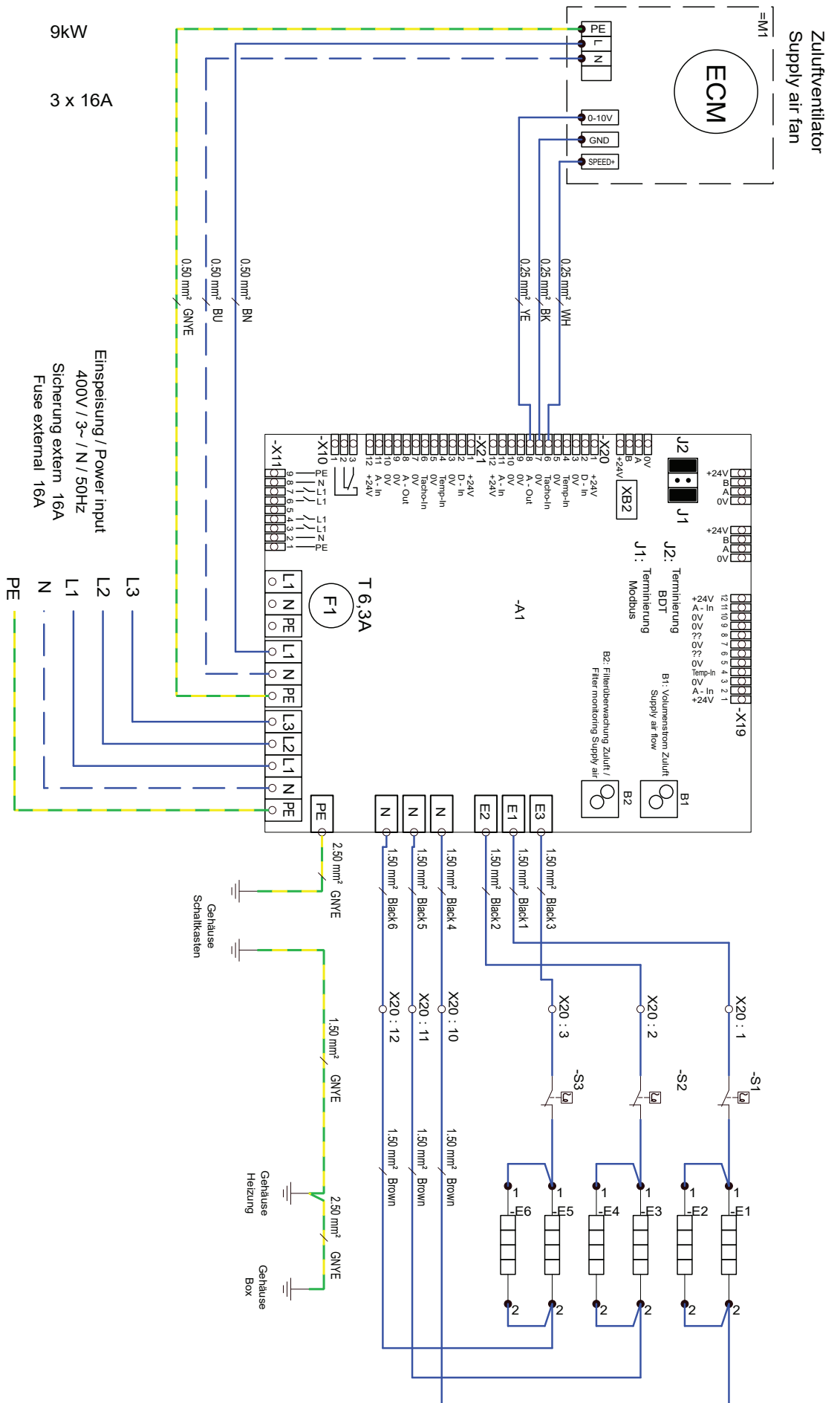

Einspeisung / Power input
 400V / 3~ / N / 50Hz
 Sicherung extern 16A
 Fuse external 16A

19.4. Circuit diagram controls

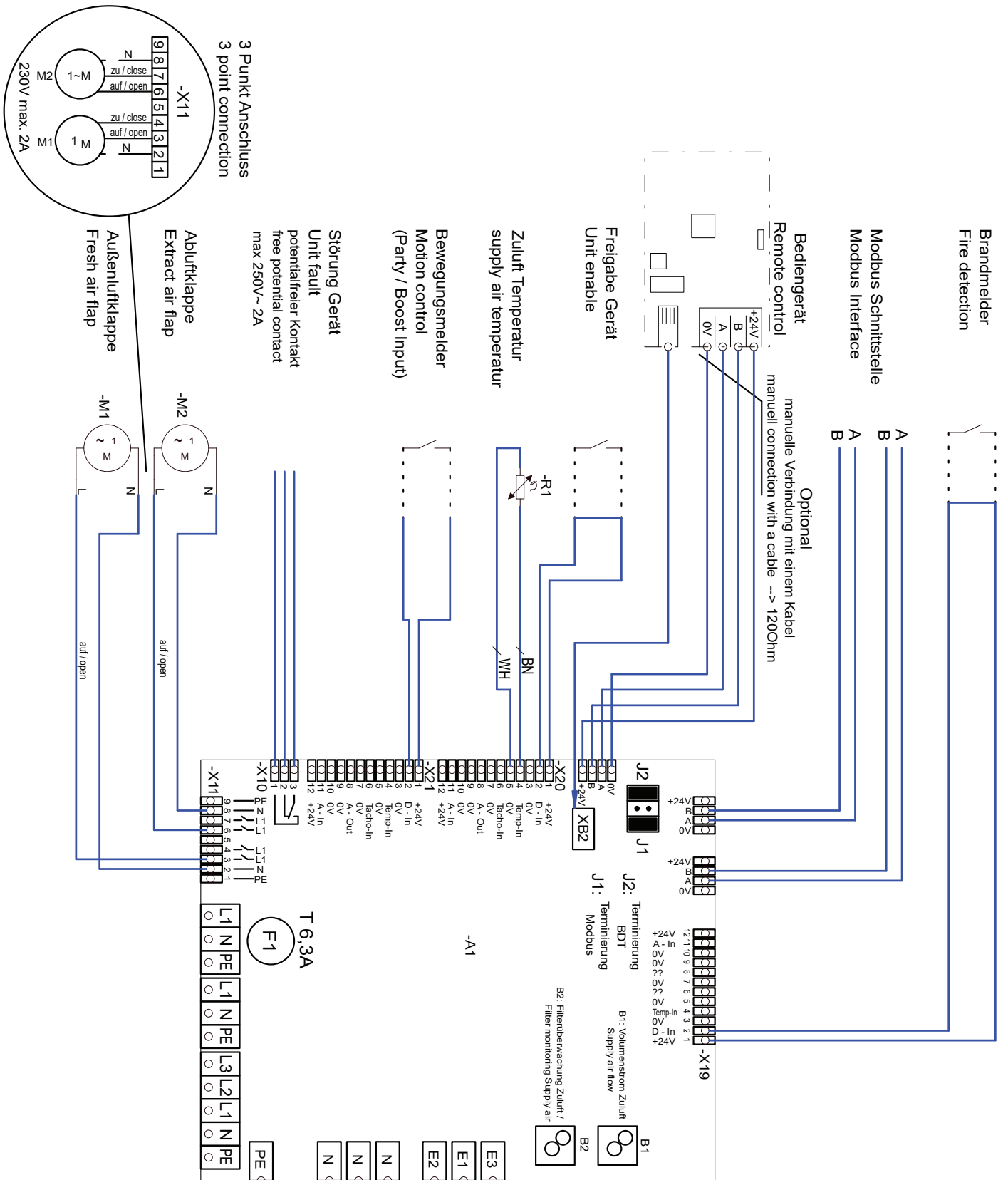

19.5. Connection external extract fan

Meldungsquelle: Tacho Signal oder Open-collector
 malfunction-source: speed-signal or open-collector

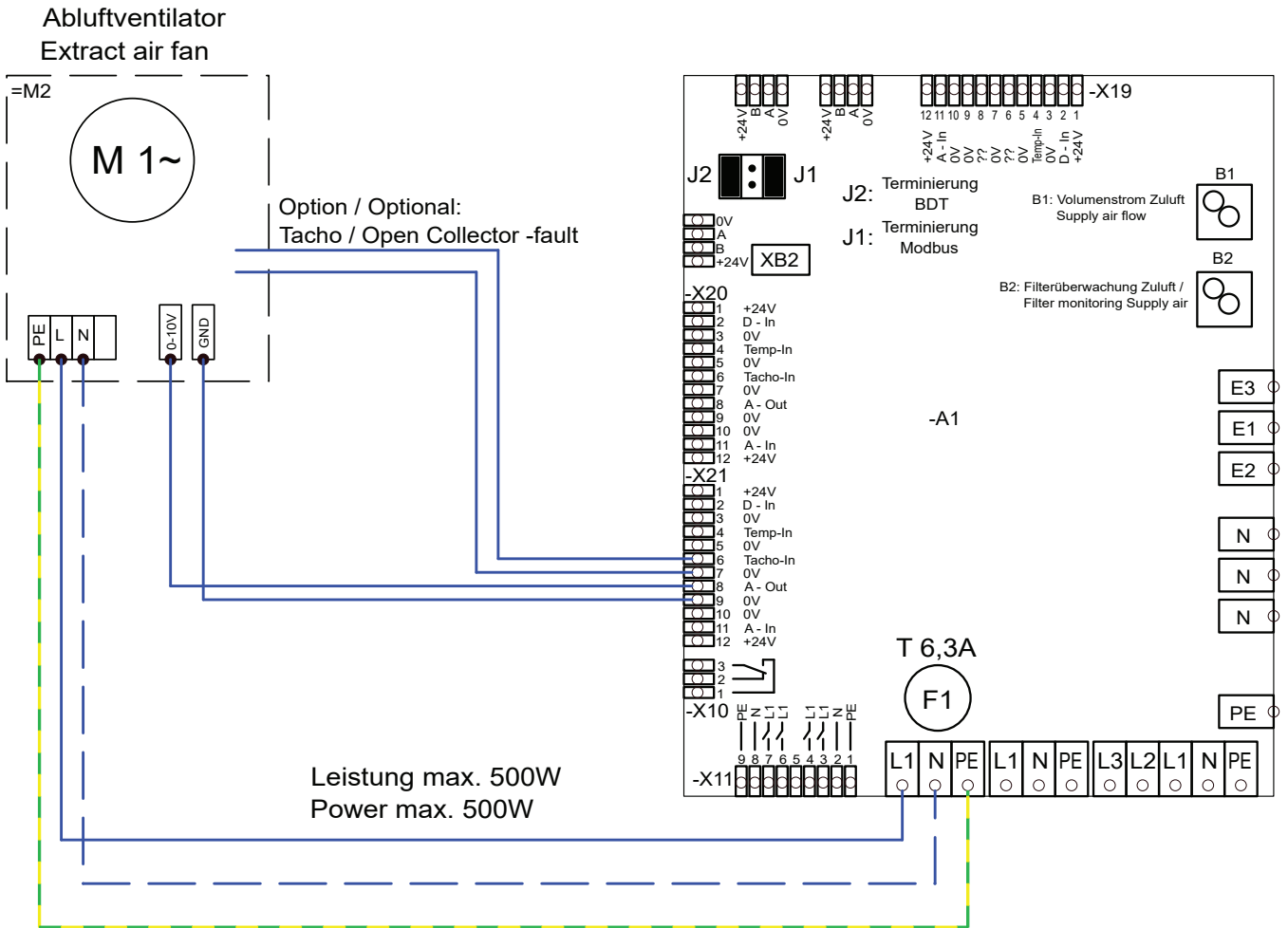

19.6. Connection pressure sensor for constant pressure control

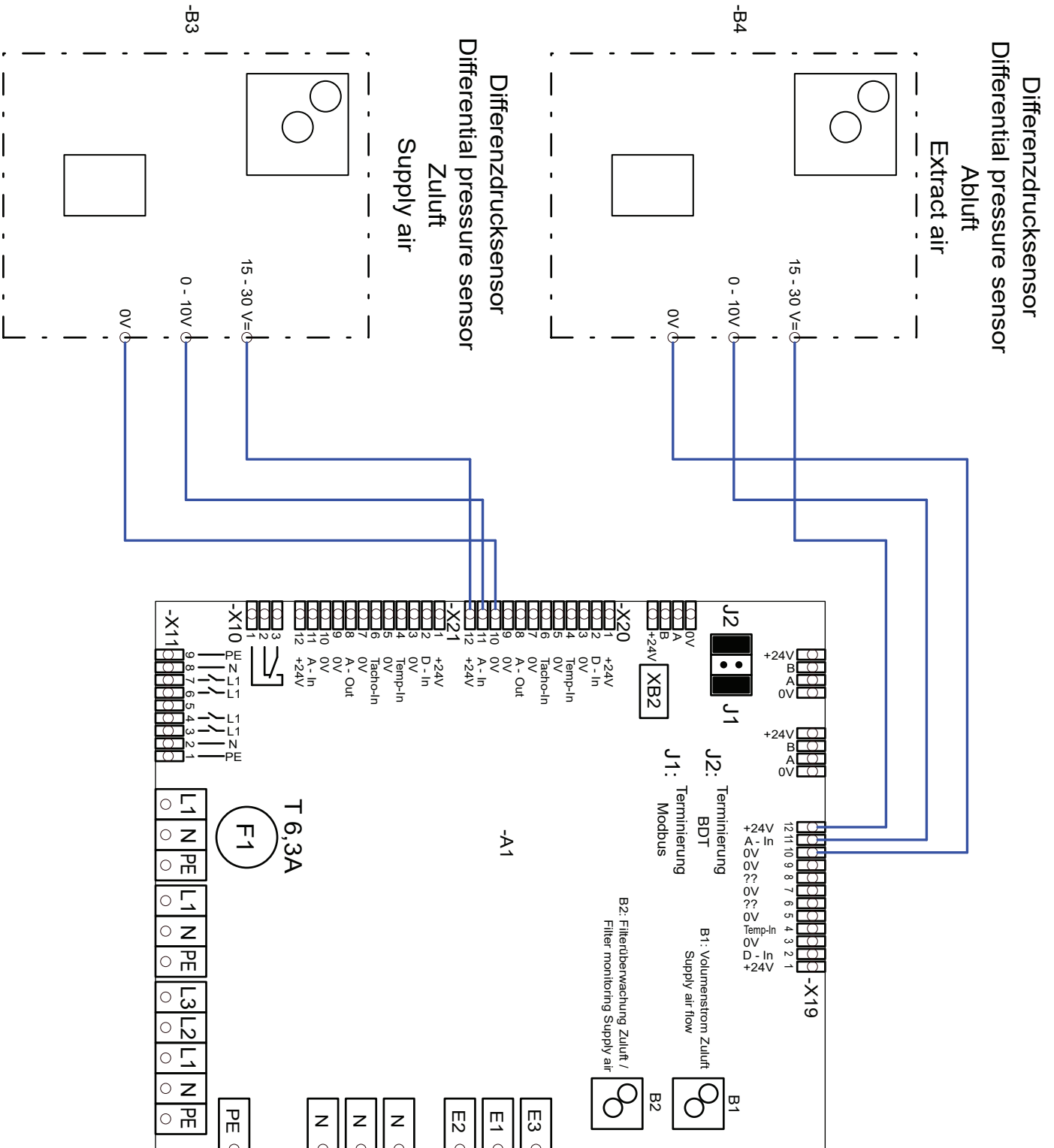

19.7. External sensor (CO2, VOC)

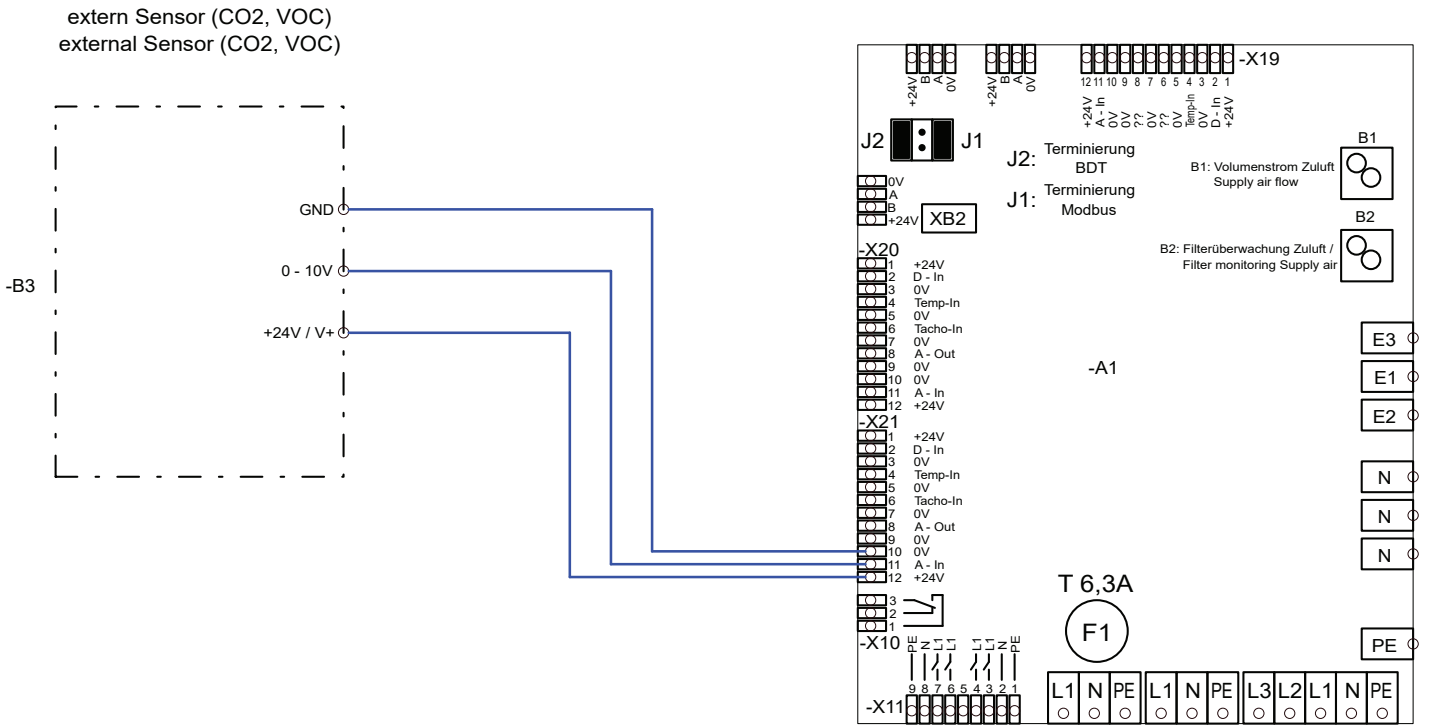

19.8. External sensor (humidity)

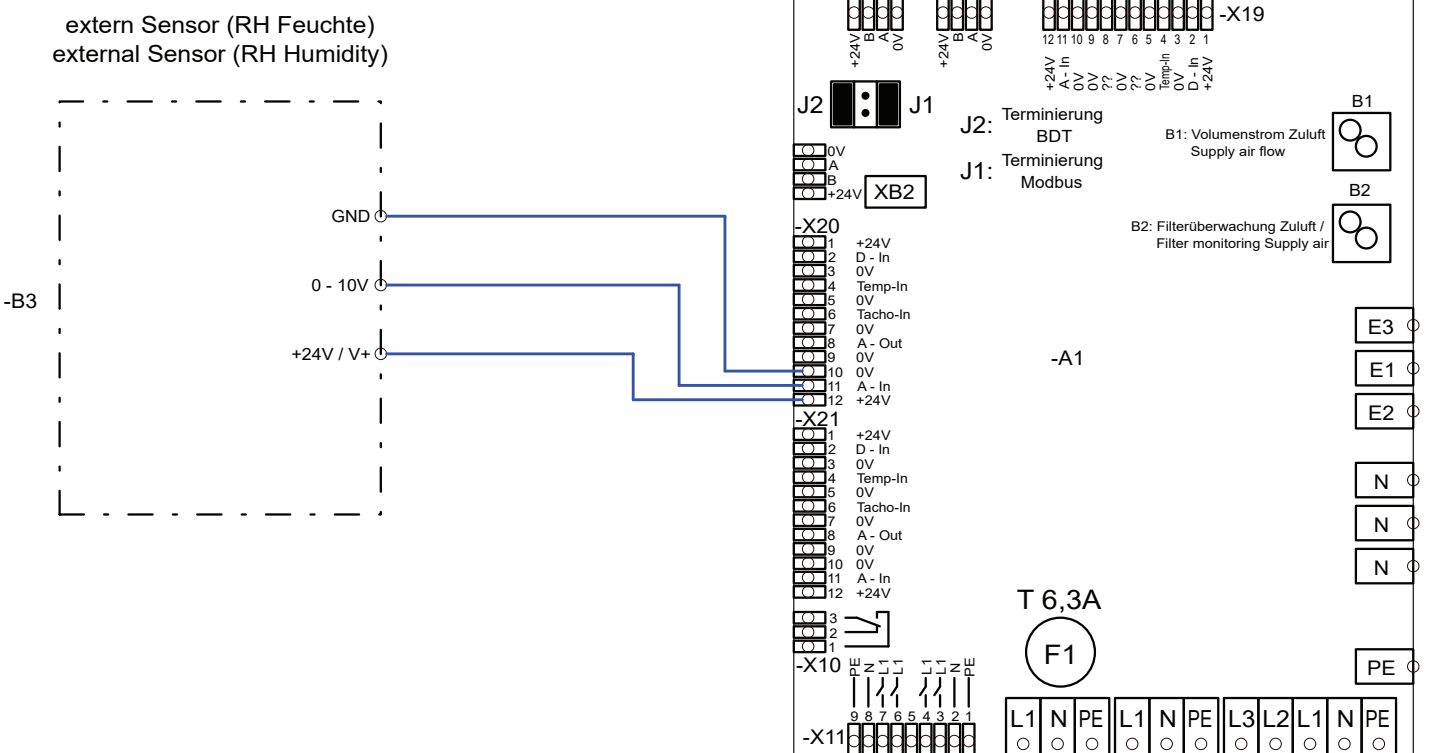

19.9. Connection for external control

10V: max. Ventilator Drehzahl
 2V : min. Ventilator Drehzahl
 <2V: Gerät Aus

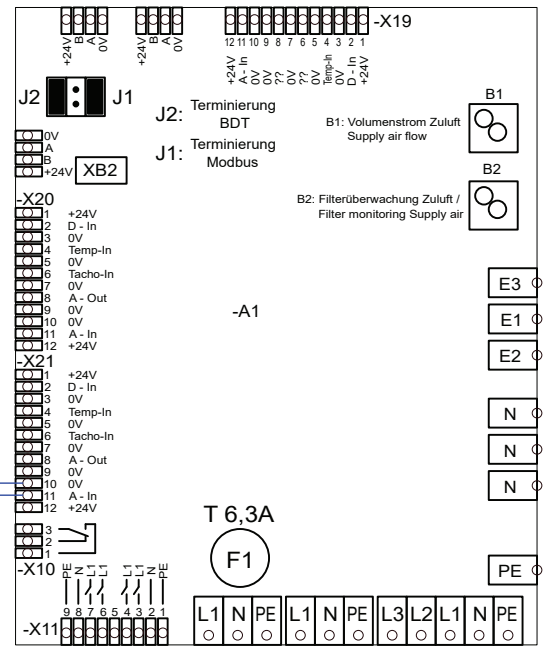
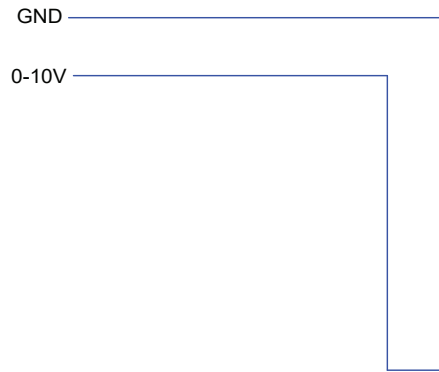

19.10. Connection Roomtemperatur Sensor

Optionaler / Optional
 Raumtemperatur / Roomtemperatur

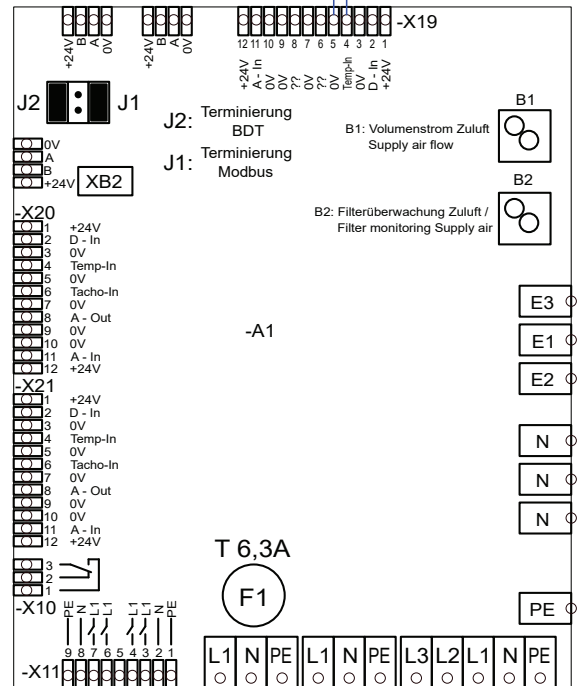
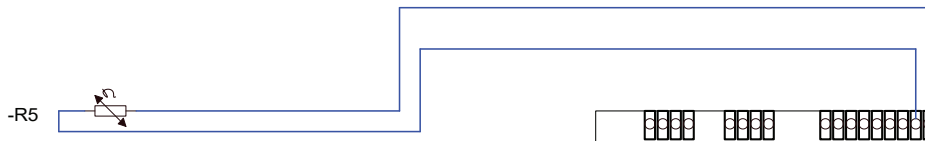

MAICO Elektroapparate-Fabrik GmbH
Steinbeisstr. 20
78056 Villingen-Schwenningen
Tel. +49 7720 694-0
Fax. +49 7720 694-263
info@maico.de
www.maico.de

Information updated
print 24.03.2025
mzf_pb_02d_k11102_en

We reserve the right to make changes

Language:
English